

EDN[®]

VOICE OF THE ENGINEER

JAN 6

Issue 1/2011
www.edn.com



An engineer walks into a bar ... Pg 56

EDN.comment: Die size does not determine IC cost Pg 9

Signal Integrity: The undo machine Pg 18

Lithography for sub-20-nm processes Pg 21

Design Ideas Pg 47

IC VENDORS SEEK GREEN APPLICATIONS

Page 26

CHARGE-RECOVERY CIRCUIT MAXIMIZES PIEZOELECTRIC- ACTUATOR EFFICIENCY

Page 22

USING ENHANCED TRIGGERING TO VERIFY AND DEBUG COMPLEX DESIGNS

Page 36

LESSONS FROM DESIGNING BATTERY- MANAGEMENT SYSTEMS

Page 40



www.digikey.com

MachXO™ PLD

MachXO. THE ALL-IN-ONE PLD.

Do more with the most versatile, non-volatile PLD for low-density applications. Loaded with flexible user I/Os, embedded memory, PLLs, and more—now you have the freedom to create and design with a single, easy-to-use, instant-on, and secure PLD.

Discover all you can do with the MachXO PLD family at:
latticesemi.com/machxo



Lattice
Semiconductor
Corporation

PREMIUM SELECTION PERSONALIZED SERVICE



On Orders entered by
800 pm
STANDARD
NEXT-DAY DELIVERY
SAME-DAY SHIPPING



Authorized distributor for more than 440 of the world's most trusted manufacturers.*

The industry's broadest product selection available for immediate delivery

www.digikey.com
1.800.344.4539

*Digi-Key is an authorized distributor for all supplier partners. New products added daily. © 2011 Digi-Key Corporation, 701 Brooks Ave. South, Thief River Falls, MN 56701, USA



Go ahead: define your most exacting waveform.



Generate a most exacting output.

You're developing new technologies every day that are faster, more efficient and imaginative. Agilent 33500A Series function/arbitrary waveform generators provide your waveforms with the highest signal fidelity. With

33521A and 33522A

30 MHz sine, square, pulse bandwidth

250 MSa/s, 16-bit sampling

Point-by-point arbitrary waveforms

Dual-channel coupling and tracking

10x better jitter than anything in its class you have unparalleled control of signal frequency. And new breakthrough technology provides an unprecedented ability to generate arbitrary waveforms. That's confidence. That's Agilent.

© 2010 Agilent Technologies, Inc.

**Agilent and our
Distributor Network**
Right Instrument.
Right Expertise.
Delivered Right Now.

 **METRICTEST**
6,000 instruments. One source.

866-436-0887
www.metrictest.com/agilent

Get 10% off the dual-channel 33522A
www.metrictest.com/agilent/funcgen.jsp



Agilent Technologies



EDN ^{1.6.11} contents



Using enhanced triggering to verify and debug complex designs

36 The use of sophisticated triggers plays a key role in identifying problems from design verification through to debugging and troubleshooting.

by Jit Lim,
Tektronix Inc

IC vendors seek green applications

26 With devices ranging from DSPs to Hall-effect sensors, semiconductor manufacturers are looking to improve efficiency in applications ranging from telecommunications to automotive electronics.

by Rick Nelson,
Editor-in-Chief

Charge-recovery circuit maximizes piezoelectric-actuator efficiency

22 The never-ending drive for lower power and longer battery life maximizes the need for accurate piezoelectric actuators. A charge-recovery method reduces piezoelectric-actuator input power by exploiting energy transfer between an inductor and piezoelectric-actuator capacitance.

by Mike Augarten, Allergan

Lessons from designing battery-management systems

40 Available battery-fuel-gauge products bring challenges and limitations, especially when you apply them to the battery-management function. Here are some guidelines for engineers who are designing both portable devices and the batteries to power them.

by David Gunderson,
Micro Power Electronics



Dilbert 14

12 Xilinx adds FPGA-DSP-development kits

14 CST teams with Cadence on PCB, package co-design

14 IC manages FlexRay traffic

16 Scopes and probes target power, performance, and price sweet spot

17 Multicore DSPs and base-station SOC target use in embedded processing

COVER: PHOTO-ILLUSTRATION BY TIM BURNS.
CHIPS: CRAFTVISION/ISTOCKPHOTO.COM;
LANDSCAPE: AVTG/ISTOCKPHOTO.COM

DESIGN IDEAS

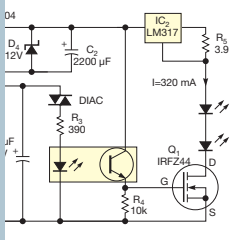

47 Test continuity with an LED

48 Flash an LED from ac-mains power

50 Reliable 555 timer doesn't falsely trigger

50 Transistors drive LEDs to light the path

51 Use an optocoupler to make a simple low-dropout regulator



- Programmable Room Sensor
- Central Heating Unit
- Programmable Radiator Thermostat
- Burner Control Unit
- Solar Control Unit
- Air Conditioning System
- Hot Water Dispenser

HVAC
(Heating, Ventilating, and Air Conditioning)

Metering

- Smart Meter
- Heat Meter
- Heating Cost Meter
- Water Meter/Hot Water Meter/ Gas Meter/Pre-Paid Meter
- Power Meter (Single-Phase)
- Power Meter (Three-Phase)
- Water Meter
- Gas Meter

- Detector
- Smoke Detector
- Sounders and Strobes
- Access Control System
- Automatic Fire Door
- Alarm Control Panel
- Emergency Lighting Control
- Surveillance Camera
- Smart Cards
- Camera Control
- Gas Leak Alarms

Safety and Security

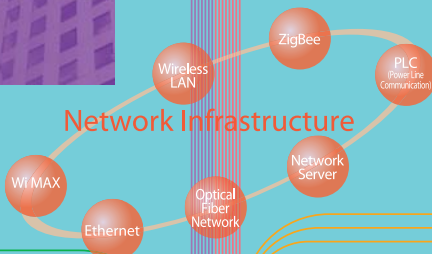

Lighting

- LED Lighting
- Blind Control
- Emergency Lighting Control
- Electronic Timer
- Motion Detector
- Central Control Panel
- Electronic Ballast, Neon Lighting



- Key Features**
- Connectivity
 - Security
 - High Performance
 - Compact
 - Impressive Lineup
 - Low Power
 - Convenient Function
 - Human Interface

Get started now for smart development at www.renesas.com/smart

Renesas Electronics Corporation

Green Solutions ready for you



contents 1.6.11

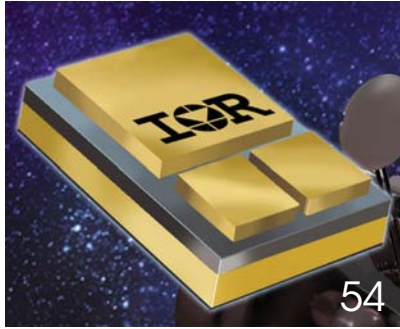

DEPARTMENTS & COLUMNS

- 9 **EDN.comment:** Die size does not determine IC cost
- 18 **Signal Integrity:** The undo machine
- 21 **Inside Nanotechnology:** Lithography for sub-20-nm processes
- 53 **Supply Chain:** Inventory's bumpy road to smooth somewhat this year
- 54 **Product Roundup:** Discrete Semiconductors
- 56 **Tales from the Cube:** An engineer walks into a bar ...

EDN online contents www.edn.com

ONLINE ONLY

Check out these Web-exclusive articles:

Why modems are going soft

A new approach to modem development separates the modem-specific software from the hardware and, therefore, has a profound impact on the platform-design flow.

→ www.edn.com/110106toca

First-silicon encounters

The four most common problems with first silicon are scan-chain failures, excess leakage current, signal integrity, and timing.

→ www.edn.com/110106tocc

Abu Dhabi: High-tech mecca or mirage?

The goal of ATIC (Advanced Technology Investment Co), the majority owner of GlobalFoundries, is to make Abu Dhabi the next semiconductor hot spot.

→ www.edn.com/110106toccc

How-to articles and Design Ideas from Jim Williams



An EDN contributor since the early 1980s, Linear Technology's Jim Williams consistently turns out technical articles that rank at or near the top of our Readers' Choice lists. Check out the online archive of Williams' articles.

→ www.edn.com/jimwilliams

IC Design Corner



Technical Editor Mike Demler's IC Design Corner blog provides analysis and discussion on the engineering challenges of IC design and applications, including full custom to field-programmable systems on chips, EDA tools and methods, and advanced semiconductor processes.

→ www.edn.com/110106toccd

EDN® (ISSN#0012-7515) is published semimonthly, 24 times per year, by UBM Electronics, 11444 W. Olympic Blvd., Los Angeles, CA 90064-1549; 310/445-4200; FAX 310/445-4299. Periodicals postage paid at Los Angeles, CA, and at additional mailing offices. SUBSCRIPTIONS—Free to qualified subscribers as defined on the subscription card. Rates for nonqualified subscriptions, including all issues: US, \$150 one year; \$250 two years; \$300 three years. Except for special issues where price changes are indicated, single copies are available for \$10 US and \$15 foreign. For telephone inquiries regarding subscriptions, call 763/746-2792. E-mail: EDN@kmpsgroup.com. CHANGE OF ADDRESS—Notices should be sent promptly to PO Box 47461, Plymouth, MN 55447. Please provide old mailing label as well as new address. Allow two months for change. NOTICE—Every precaution is taken to ensure accuracy of content; however, the publisher cannot accept responsibility for the correctness of the information supplied or advertised or for any opinion expressed herein. POSTMASTER—Send address changes to EDN, PO Box 47461, Plymouth, MN 55447. Canada Post: Publications Mail Agreement 40612608. Return undeliverable Canadian addresses to Pitney Bowes Inc, PO Box 25542, London, ON N6C 6B2. Copyright 2011 by United Business Media. All rights reserved. Reproduction in whole or part without written permission is prohibited. Volume 56, Number 1 (Printed in USA).

IGBT Selection Made Easy

<http://mypower.irf.com/IGBT>

Conditions

Bus Voltage
Package Requirements
Current
Frequency
Short Circuit

IR
Online IGBT Selection Tool

Optimized IGBT



For more information call
1.800.981.8699 or visit

www.irf.com

International
IR Rectifier

THE POWER MANAGEMENT LEADER

Visit us at Booth 409

APEC Fort Worth Convention Center
07-09 March 2011

LabMaster Beyond the Limits

The world's only fully synchronized,
multi-channel, ultra-high bandwidth
oscilloscope system...

- ... up to 20 channels
- ... up to 45 GHz
- ... beyond the limits.

LeCroy

Visit LeCroy at **DesignCon 2011**
lecroy.com/labmaster





BY PAUL RAKO, TECHNICAL EDITOR

Die size does not determine IC cost

Years ago, you could look at the size of a semiconductor die and make a good guess about the manufacturer's cost. This situation is no longer true, even if you understand that a fine-line CMOS process costs more than a 250-nm process and CMOS processes tend to cost less than bipolar or BiCMOS processes (Reference 1). Even if you know the cost of a chip's process, you still have no idea of the required test time—an important factor because test time is a major component of an IC's cost.

Bob Reay, vice president and general manager of mixed-signal products at Linear Technology, points out that the company fabricates ADC chips with a ring of thick metallization around the periphery of the die. Linear runs large currents through this ring at test time. This step heats up the die so that the manufacturer can verify the device's temperature drift. It takes a long time to do this test, but it ensures that customers will get parts that conform to the spec.

Measuring the input-bias current of an operational amplifier is another test that takes a long time. National Semiconductor makes the LMC6041 and the LMC6001 op amps with a similar die. National tests the LMC6001 to verify the low input-bias current. The LMC6041 has a typical bias current of 2 fA, and the LMC6001 has a guaranteed maximum input-bias current of 25 fA. For this reason the LMC6001 sells for \$9.46, whereas the LMC6041 costs only \$1.07. You can buy the LMC6041 and test it yourself, but be aware that meas-

uring these tiny bias currents is a difficult task that requires special test fixtures, such as those that National Semiconductor application engineer Paul Grohe and consulting staff scientist Bob

Pease design (Reference 2). The LMC6001 costs nine times as much as the LMC6041 because National must test each part to guarantee the input-bias current and other critical specs. It

behoves every engineer to understand the implications of designing to typical and designing to maximum or minimum specifications. Purchasing agents routinely create disasters because they don't understand this issue.

Eric Schlaepfer, an application engineer at Maxim Integrated Products, laments the poor testing and specifications that many of his company's competitors perform. He says that Maxim customers complain that their chips cost more than those from some second-tier analog companies. Schlaepfer points out that Maxim could sell parts for a nickel each if there were no specs or data sheet. The tables in a

data sheet represent a legal contract between the semiconductor vendor and its customers. "I look at the data sheets for these cheaper competitive parts," Schlaepfer says. "They have half the specification of our parts." He is not saying that the competitors' specs are twice as bad but that the competitors don't bother to test many specs at all or don't test over multiple temperatures or supply voltages. All of these tests require time, which means you are paying for a better and more consistent part.

Reza Moghimi, application-engineering manager at Analog Devices, recently discussed the company's line of voltage references (Reference 3). He mentioned that Analog Devices tests its best parts for drift over time. This approach does not mean testing each product for a year before selling it. The company tests batches of parts for thousands of hours before it can confidently publish a specification in the data sheet. "ADI has a reputation for selling high-performance parts that medical and scientific customers have come to depend on," Moghimi says. "Since long-term drift is important to these customers, ADI makes sure to specify that parameter." All this testing has nothing to do with die size but certainly adds significantly to the devices' manufacturing cost.

So, it is naive to think that a small analog die should have a low cost. The IC process, the testing, the package, the service, and the reputation of the company selling the parts have nothing to do with die size. These factors will be the most important aspect in the success of your designs. **EDN**

REFERENCES

- 1 Rako, Paul, "Integration in the other direction," *EDN*, Jan 21, 2010, pg 24, <http://bit.ly/aiAc0t>.
- 2 Rako, Paul, "Measuring nanoamperes," *EDN*, April 26, 2007, pg 42, <http://bit.ly/hqOJpG>.
- 3 Rako, Paul, "Voltage references hold steady," *EDN*, Oct 21, 2010, pg 38, <http://bit.ly/dsFZ96>.

Contact me at paul.rako@ubm.com.

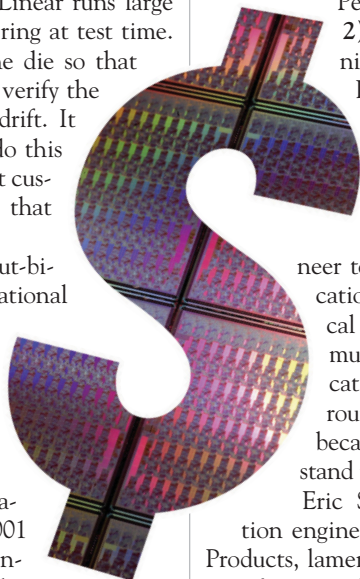

Accelerate Your Projects into the Future

AEROCON

AEROSPACE • AVIATION • DEFENSE



FEBRUARY 8-10, 2011
Anaheim Convention Center
Anaheim, California

MARCH 16-17, 2011
Orange County Convention Center
Orlando, Florida

MARCH 14-15, 2012
Fort Worth Convention Center
Fort Worth, Texas

**Introducing the new conference and exhibition
for the aerospace and defense industries**

Featuring suppliers for the design and production of aerospace and defense products, including:

- ▶ Software
- ▶ Materials
- ▶ Sub-Assemblies
- ▶ Electronics
- ▶ Machinery
- ▶ Components
- ▶ Contract Services
- ...and much more!



For more information on attending or exhibiting, visit:

AeroConShows.com

Promo Code: AA

EDN

PUBLISHER, EDN WORLDWIDE

Russell E Pratt, 1-781-869-7982;
russell.pratt@ubm.com

ASSOCIATE PUBLISHER, EDN WORLDWIDE

Judy Hayes, 1-925-736-7617;
judy.hayes@ubm.com

EDITOR-IN-CHIEF, EDN WORLDWIDE

Rick Nelson
Test and Measurement, DFX
1-781-869-7970;
richard.nelson@ubm.com

MANAGING EDITOR

Amy Norcross
Contributed technical articles
1-781-869-7971;
amy.norcross@ubm.com

MANAGING EDITOR—NEWS

Suzanne Deffree
Electronic Business, Distribution
1-631-266-3433;
suzanne.deffree@ubm.com

SENIOR TECHNICAL EDITOR

Brian Dipert
*Consumer Electronics,
Multimedia, PCs, Mass Storage*
1-916-548-1225;
brian.dipert@ubm.com

TECHNICAL EDITOR

Margery Conner
*Power Sources, Components,
Green Engineering*
1-805-461-8242;
margery.conner@ubm.com

TECHNICAL EDITOR

Mike Demler
EDA, IC Design and Application
1-408-384-8336;
michael.demler@ubm.com

TECHNICAL EDITOR

Paul Rako
Analog, RF, PCB Design
1-408-745-1994;
paul.rako@ubm.com

DESIGN IDEAS EDITOR

Martin Rowe,
Senior Technical Editor,
Test & Measurement World
edndesignideas@ubm.com

SENIOR ASSOCIATE EDITOR

Frances T Granville, 1-781-869-7969;
frances.granville@ubm.com

ASSOCIATE EDITOR

Jessica MacNeil, 1-781-869-7983;
jessica.macneil@ubm.com

CONSULTING EDITOR

Jim Williams,
Staff Scientist, Linear Technology
edn.editor@ubm.com

CONTRIBUTING TECHNICAL EDITORS

Dan Strassberg,
strassbergedn@att.net
Nicholas Cravotta,
editor@nicholascravotta.com
Robert Cravotta
robert.cravotta@embeddedinsights.com

COLUMNISTS

Howard Johnson, PhD, Signal Consulting
Bonnie Baker, Texas Instruments
Pallab Chatterjee, SiliconMap
Kevin C Craig, PhD, Marquette University

LEAD ART DIRECTOR

Marco Aguilera

ASSOCIATE ART DIRECTOR

Tim Burns

PRODUCTION

Michael Ciardiello,
Director of Premedia Technologies
Jeff Tade,
Production Director
Brian Wu,
Publications Production Manager
Jeff Polman, Derric Treece,
Senior Production Artists
William Baughman, Lucia Corona
Ricardo Esparza,
Production Artists

EDN EUROPE

Graham Prophet, Editor, Reed Publishing
prophet@reedbusiness.fr

EDN ASIA

Wai-Chun Chen, Group Publisher, Asia
waichun.chen@ubm.com
Kirtimaya Varma, Editor-in-Chief
kirti.varma@ubm.com

EDN CHINA

William Zhang,
Publisher and Editorial Director
william.zhang@ubm.com
Jeff Lu, Executive Editor
jeff.lu@ubm.com

EDN JAPAN

Katsuya Watanabe, Publisher
katsuya.watanabe@ubm.com
Ken Amemoto, Editor-in-Chief
ken.amemoto@ubm.com

EXECUTIVE OFFICERS

Paul Miller,
Chief Executive Officer
Fred Gysi,
Chief Financial Officer
Mike Deering,
Chief Technology Officer
Ron Wall,
Senior Vice President, Publications
Kevin O'Keefe,
Senior Vice President, Events Division
Roger Burg,
Vice President, Operations
Jason Brown,
Vice President, E-media

“I can't say
enough about
...the efficiency
of speaking
engineer-to-
engineer...”

New Product Development Engineer,
Fluid Controls Manufacturer

MAXIMUM Support

“Mill-Max is willing to come to us, consult, and turn projects around quickly. Other high volume shops don't offer that kind of attention unless your part order runs into the millions.”

At **Mill-Max** we don't believe that service and technical support should be dependent on the size of an order. In fact, we're never content with simply filling an order...not if we can see ways to improve component functionality or simplify the manufacturing process.

“...with a design we thought would require a lot of secondary operations...they found a way to machine it at once...resulting in a very functional, very low-cost part.”



Our connectors speak for themselves...so do our customers.

To view our Design Guide, new product offerings and request a datasheet with free samples, visit www.mill-max.com/EDN612



UBM
Electronics

EDN, 33 Hayden Avenue, Lexington, MA 02421. www.edn.com. **Subscription inquiries:** 1-763-746-2792; EDN@kmpsgroup.com. **Address changes:** Send notice promptly to PO Box 47461, Plymouth, MN 55447. Please provide an old mailing label as well as your new address. Allow two months for the change.

UBM Electronics, 11444 W. Olympic Blvd., Los Angeles, CA 90064-1549;
1-310-445-4200; fax: 1-310-445-4299.

pulse

INNOVATIONS & INNOVATORS

Xilinx adds FPGA-DSP-development kits

Xilinx has announced DSP-development kits for high performance, low cost, and acceleration of system performance through coprocessing. The company based the Virtex-6 FPGA-DSP-development kit on the LX240T FPGA. It targets high-performance signal-processing applications, such as aerospace and defense, medical technology, high-performance computing, and next-generation wireless communications. An FPGA-mezzanine card connects the Virtex-6 ML605 development board to a pair of Texas Instruments (www.ti.com) ADCs and DACs. The dual-channel, 14-bit ADCs operate at 250M samples/sec, and a dual-channel DAC provides 16-bit resolution at 800M samples/sec. Design-environment support includes the Xilinx ISE (integrated-software-environment) design suite for The MathWorks (www.mathworks.com) Matlab Simulink with SysGen and the AutoESL (electronic-system-level) HLS (high-level-synthesis) tools.

The entry-level Spartan-6 FPGA-DSP-development kit provides 6.7-times more performance per watt than does a discrete DSP and targets designs requiring minimum cost and low system power. The kit's baseboard includes a Spartan-6 LX150T FPGA with integrated transceivers for high-speed system connectivity. All of the new development kits support the AMBA (advanced microcontroller-bus-architecture) AXI4 (Advanced Extensible Interface 4). They include digital upconversion/down-conversion reference designs that you can use as is or modify through an RTL (register-transfer-level) design flow, model-based design with Matlab and Simulink, or high-level C-language synthesis.

The Spartan-6 FPGA coprocessing kit enables you to reduce application bottlenecks by using the FPGA to offload high-performance

DSP functions to achieve system acceleration. The Avnet (www.avnet.com) development kit integrates the Spartan-6 LX45T FPGA with Texas Instruments' low-power OMAP (Open Multimedia Applications Platform) L-138 processor, which employs the ARM926EJ-S and TI's C674x DSP core. To help engineers start designing immediately, the kit includes Texas Instruments' Code Composer Studio. The kit also supports embedded-Linux development, along with the SysGen flow for model-based design and RTL flows.

The Virtex-6 FPGA-DSP kit, which includes the ML605 development board, Xilinx ISE System Edition, AXI4 DSP IP (intellectual property), a Virtex-6 FPGA-targeted reference design, and TI ADC/DAC technology on an FPGA-mezzanine daughtercard from 4DSP (www.4dsp.com), sells for \$3995. The Spartan-6 FPGA-DSP kit includes the Avnet LX150T development board, Xilinx ISE System Edition, AXI4 DSP IP, and a Spartan-6 FPGA-targeted reference design and sells for \$1995. The Spartan-6 FPGA coprocessing kit is available for \$1695. —by Mike Demler

▷Xilinx, www.xilinx.com.

TALKBACK

"The great place for this device would be going through airport security, to keep track of one's computer. The buzzer will need to be very loud and able to sound long enough to chase down the punk that steals said laptop. Of course, the TSA may mistake it for a bomb and shoot the user."

—Engineer and writer William Ketel, in *EDN's* Talkback section, at <http://bit.ly/eq5xmD>. Add your comments.



The Virtex-6 FPGA-DSP-development kit targets high-performance signal-processing applications, such as aerospace and defense, medical technology, high-performance computing, and next-generation wireless computing.

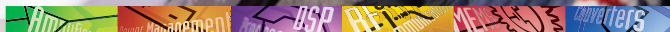

Analog Devices: enabling the designs that make a difference in people's lives

signostics

ADI helps Signostics deliver portable ultrasound imaging quickly and affordably with their new personal ultrasound system.



At ADI, continuous innovation in signal processing technologies makes possible the design of sophisticated medical diagnostic and monitoring systems, as well as health and wellness devices relied on by care providers and patients around the globe. We're pioneering technologies that hold the promise of accurate, affordable home monitoring and assistance for heart health, high blood pressure, diabetes, and patient activity. For 40 years, engineers have relied on our analog and mixed-signal ICs to set performance standards and on our people for their system expertise. This tradition continues. Explore ADI healthcare solutions at: www.analog.com/healthcare.

MAKEADIFFERENCE

www.analog.com/makeadifference



CST teams with Cadence on PCB, package co-design

CST (Computer Simulation Technology) recently signed a joint-marketing agreement with Cadence Design Systems. Cadence and CST are collaborating to offer an effective workflow for PCB and package-layout co-design in high-speed and mixed-RF systems. The companies report that their applications teams will work together to address customer requirements.

The fact that chip packages and PCBs operating at high speeds can experience unwanted noise, reflections, and crosstalk, as well as other undesirable effects that can affect performance and energy consumption, spurred the companies to collaborate to solve these problems. The companies are focusing on prelayout analysis and post-layout verification of performance to ensure that a system meets specifications, minimizing undesired effects and cost.

The Cadence/CST approach involves fully automated workflows employing 3-D extraction to accurately characterize all critical nets, discontinuities, and 3-D components, such as wire bonds and BGAs. The goal is to provide confidence in device performance before a customer builds a first prototype.

The companies are offering two possible workflows. The first, an EM (electromagnetic)-centric approach, focuses on CST's full-wave environment and allows complete access to the tool's extensive preprocessing and postprocessing capabilities, as well as parameterization and optimization. This approach also facilitates other EM studies involving the effects of an enclosure, for example. The approach supports direct import of .brd, .mcm, and .sip files, and users can perform all editing and selection within the full-wave environment.

The second, EDA-centric, approach assumes that the user has expertise in the Cadence layout tool and allows users to run the full-wave simulation as a fully automatic background process with back annotation of results to the layout environment. This approach generates meaningful and accurate 3-D characterization data, but it requires minimal knowledge of the full-wave environment on the part of the user.

Jonathan Oakley, vice president of sales and marketing at CST of America, says that the Cadence/CST joint effort demonstrates the two companies' commitment to offering tools that solve high-speed pack-

EE The approach involves automated workflows employing 3-D extraction to accurately characterize all critical nets.

age, SIP (system-in-package), and PCB problems. The signing of a joint-marketing agreement ensures a high level of commitment, ultimately benefiting customers with greater expertise and more effective approaches from both companies.

Brad Griffin, product-marketing director for SIP, IC packaging, and PCB high-speed products at Cadence Design Systems, says that Cadence Silicon Realization products combine with CST's 3-D full-wave extraction environment to align with Cadence's EDA360 vision, whose goal is to provide a 360° vision of an EDA industry that serves integration and design-creation functions.

—by Rick Nelson

- ▶ **Cadence Design Systems**, www.cadence.com.
- ▶ **CST of America**, www.cst.com.

IC MANAGES FLEXRAY TRAFFIC

Austriamicrosystems has introduced the AS8223, a monolithic FlexRay Standard Version 2.1 Revision B-compliant Active Star device. The AS8223 manages communication traffic among four FlexRay branches of a network, expandable to more branches through an Interstar interface. The four branches of the AS8223 operate as a FlexRay receiver and transmitter, whereby one of the communication paths operates as a receiver and the others operate as transmitters.

The device comes with a host-controller interface, enabling active control of power modes. The AS8223 FlexRay Active Star Device is available in a 9×9-mm, 44-pin MLF package and operates over a -40 to +125°C temperature range and from 5.5 to 40V power supplies. It sells for \$8 (1000). For more, go to <http://bit.ly/hCcxy1>. —by Rick Nelson

▶ **Austriamicrosystems**, www.austriamicrosystems.com.



The AS8223, a monolithic FlexRay Standard Version 2.1 Revision B-compliant Active Star device, manages communication traffic among four FlexRay branches of a network, expandable to more branches through an Interstar interface.

01.06.11

DILBERT By Scott Adams

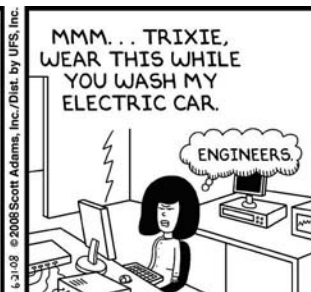

Twice the Power Half the Size

New family of high-density power components enables fast, adaptable designs

Example Application

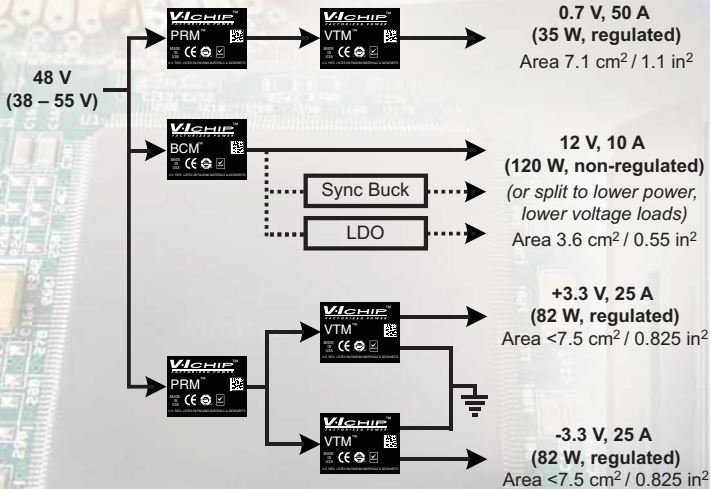

Half-Chip	V _{IN} (V)	V _{OUT} (V)	I _{OUT} (A)	P _{OUT} (W)
BCM	48	12	10	120
PRM	48	5-55	4	200
VTM	48	12	10	135
		6	20	100
		4	25	115
		2	40	88.5
		1.5	50	80



- 1/32 brick footprint
- Up to 97% efficiency, up to 1300 W/in³
- 200W PRM™ Regulator
- 50A VTM™ Current Multiplier
- 120W BCM™ Bus Converter

Half-size V•I Chip modules increase design flexibility for configurable, high-density, low-profile power system solutions and effectively address lower power applications with better efficiency and state-of-the-art performance.



Visit
www.vicorpower.com/rp/half-chip_edn
 for more information
 and to order samples online.

All parts available from stock NOW!

Scopes and probes target power, performance, and price sweet spot

Tektronix recently introduced the MSO (mixed-signal-oscilloscope)/DPO (digital-phosphor-oscilloscope) 5000 series and the high-bandwidth, low-capacitance TPP1000 and TPP0500 passive voltage probes. Features include FastAcq, which uncovers elusive problems by capturing more than 250,000 waveforms/sec; FastFrame,

upgrade the DPOs in the field to MSOs.

DPX technology with FastAcq enables you to quickly see signal problems with a 2-GHz acquisition rate and then use more than 350 trigger combinations to capture subsequent occurrences of similar events. Extensive triggers for serial- and parallel-bus content enable fast validation of bus opera-

ultrahigh-resolution-acquisition mode is essential for making accurate timing measurements for setup-and-hold, clock-delay, signal-skew, and glitch characterization. It acquires as many as 10,000 points with 60.6-psec resolution.

Using the MSO/DPO5000 series' optional support for automated trigger and decode of I²C (inter-integrated-circuit),

benefits of passive probes—high input dynamic range, robust mechanical design, and lower cost. These high-impedance, 10-M Ω -input-resistance probes limit their effect on circuits with capacitive loading of just 3.9 pF at the probe tip. The TPP1000 passive probes also deliver bandwidth of 1 GHz. Every model in the MSO/DPO5000 series and the new MSO/DPO4000B series includes the TPP probes at no additional cost.

To address higher-voltage applications, faster signals, and low-power circuits, the new MSO/DPO4000B series offers improved digital acquisition and twice the standard record length of its predecessors. The series includes six models with bandwidth of 350 MHz at 2.5G samples/sec to 1 GHz at 5G samples/sec, along with standard one- and two-channel record lengths of 20 million points.

Ideal for low-speed and mid-speed serial debugging, the series adds support for 10/100 BaseT/TX Ethernet and MIL-STD (military-standard)-1553 buses along with added limit- and mask-testing analysis capabilities. The series is the industry's first oscilloscope-based trigger, decode, and search tool for Ethernet buses. The series also features mounting to network drives and LXI (local-area-network extensions for instrumentation) Class C compliance.

Prices for the new scopes and probes range from \$11,400 to \$27,400 for the MSO/DPO5000 Series and from \$10,400 to \$20,300 for the MSO/DPO4000B Series. Each scope comes with four of the TPP-series probes. Additional TPP1000 and TPP0500 probes cost \$885 and \$585, respectively.

—by Dan Strassberg

▶ Tektronix Inc, www.tektronix.com.



The 2-GHz-bandwidth MSO5204 mixed-signal oscilloscope targets the scope market's sweet spot with a wide array of new and improved features and attractive pricing (left). For signal frequencies of 1 GHz or lower, the TPP probes represent an attractive alternative to more expensive and less rugged active probes. The 3.9-pF input capacitance is less than half that of any other passive probe (right).

whose long records and segmented memory acquire high-resolution data over long periods; built-in tools for in-depth analysis of complex designs; and a Windows-based user interface for easy networking and intuitive operation.

The series includes eight models whose analog bandwidths range from 350 MHz to 2 GHz and which offer 10G-sample/sec/channel one- and two-channel-mode acquisition or 5G samples/sec/channel on the narrower-bandwidth models. Each model has four analog channels. Record lengths range from 12.5 million to 250 million points/channel. The MSO models also offer 16 digital channels and built-in parallel-bus trigger and decode capability. You can

tion and enable you to quickly track down system-level problems. The built-in Wave Inspector automatically searches an acquisition of as many as 250 million points to find events you have specified and mark every occurrence for fast navigation to problem areas. More than 50 automated measurements, advanced waveform math, histograms, statistics, and other built-in analysis tools allow you to validate the design or analyze the signal and determine problems' root causes.

The MSO5000 fully integrates all 16 of its digital channels into the scope, enabling you to trigger across all input channels and automatically time-correlate all analog, digital, and serial/parallel-bus events. MagniVu's

SPI (serial-peripheral interface), RS-232, and USB (Universal Serial Bus) 2.0 serial buses, you can focus on solving problems and not on manually decoding serial protocols. Optional analysis support for jitter and eye-pattern analysis, limit and mask testing, serial-compliance tests, power measurements, and DDR memory, among others, further enables you to use one instrument for a range of applications. The portable package lets you use the instruments anywhere. The scope's five-rack-unit, 8.75-in.-high package also suits it to use in automatic-test-equipment applications.

The TPP1000 and TPP0500 passive voltage probes deliver performance similar to that of active probes together with the

Multicore DSPs and base-station SOC target use in embedded processing

Texas Instruments in November introduced the TMS320C66x fixed- and floating-point DSP cores plus four new scalable C667x multicore DSP devices. The DSPs include multiple 1.25-GHz DSP cores and a media-infrastructure DSP. According to the company, they are the first 10-GHz DSPs with 320 GMACS (billion multiply/accumulate operations per second) and 160 Gflops (billion floating-point operations per second) of combined fixed- and floating-point performance on a single device. TI based the family on its new KeyStone multicore architecture, which maximizes the throughput of on-chip data flows and eliminates the possibility of bottlenecks.

TI is also introducing a wireless-base-station SOC (system on chip) with 4G-class performance. TI based the TMS320TCI6616 wireless-data-engine SOC on the new TMS320C66x DSPs and multicore KeyStone architecture. The TCI6616 also performs both fixed- and floating-point math.

The C667x DSP family includes the pin-compatible two-core TMS320C6672, four-core TMS320C6674, and eight-core TMS320C6678, along with the four-core TMS320C6670 communications SOC. Using TI's C667x multicore DSPs, infrastructure developers can now more easily design integrated, software-upgradable, power- and cost-efficient platforms in mission-critical markets involving public safety and defense, medical and high-end imaging, test and automation, high-performance computing, smart grids, and core networking.

Ramesh Kumar, TI's worldwide business manager for multicore, names as applications

advanced imaging products for wafer inspection, LCD inspection, solar-cell inspection, smart cameras for factory automation, ultrasound systems, and industrial microscopes. In the test-and-measurement area, he highlights vector signal analyzers, spectrum analyzers, vector signal generators, base-station analyzers, audio/video-quality testers, impairment generators, mobile-phone service testers, and traffic analyzers.

TI also offers the MC-SDK (multicore-software-developer kit) and a suite of multicore tools, as well as an ecosystem involving software and hardware partners. The new C667x multicore DSPs are also software-compatible with TI's C6000 DSPs, enabling vendors to reuse software.

TI developed the TCI6616 SOC to incorporate field-proven PHY (physical)-layer technology, an autonomous packet-pro-

cessing engine, and programmable DSPs. TI implements the SOCs as configurable coprocessors, which enable SDR (software-defined radio), allowing operators to move their designs to emerging standards without external components. Autonomous packet processing in the TCI6616 manages packets from both core and radio networks, offloading packet processing and freeing cycles for algorithms that enhance spectral efficiency.

—by Rick Nelson

► Texas Instruments, www.ti.com.

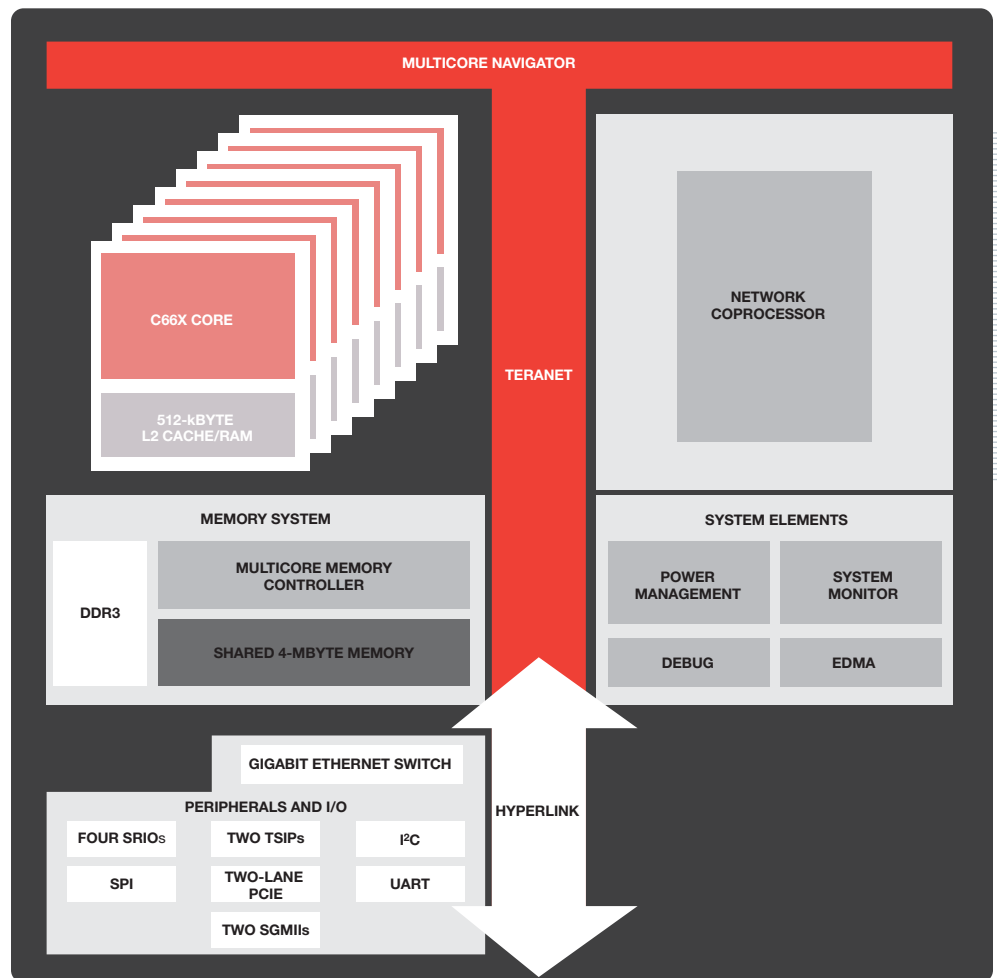

EDMA: ENHANCED DIRECT-MEMORY ACCESS
 I²C: INTER-INTEGRATED CIRCUIT
 PCIE: PERIPHERAL COMPONENT INTERCONNECT EXPRESS
 SGMII: SERIAL GIGABIT MEDIA-INDEPENDENT INTERFACE

SPI: SERIAL-PERIPHERAL INTERFACE
 SRIO: SERIAL RAPID INPUT/OUTPUT
 TSIP: TRIMBLE STANDARD INTERFACE PROTOCOL
 UART: UNIVERSAL ASYNCHRONOUS RECEIVER/TRANSMITTER

Texas Instruments' new DSPs combine multiple 1.25-GHz DSP cores to provide 10 GHz, 320 GMACS, and 160 Gflops of combined fixed- and floating-point performance on a single device.



BY HOWARD JOHNSON, PhD

The undo machine

“In the game of telephone,” I explained to my friend Chris “Breathe” Frue, “a simple phrase successively whispered through a chain of people comes out hilariously distorted. ‘Send reinforcements now’ might turn into ‘Cindy divorced Ming Chow.’ In that game, you can never regain any information you lost at any stage. Linear electronics doesn’t work that way.”

“Are you suggesting that you can somehow undo the signal distortion that some of the time-invariant processes cause?” asked Breathe, a talented musician and audio technician who wants to learn more about equalizers.

“Within reason, yes,” I replied. “That ability is the beauty of LTI [linear-time-invariant] processes, and the key to understanding all forms of equalization. You can undo almost all linear processes.”

“Which ones can’t you undo?” Breathe asked.

“In the audio world, if a graphic equalizer mildly attenuates one frequency band, you can boost it back later with another equalizer. But, if the first equalizer completely suppresses a band, setting its gain to zero, you cannot undo that action. You have lost the information in that band.”

“Show me something you *can* undo,” Breathe requested.

“Let’s examine the three-month running average,” I said. “Financial advisors use this process to smooth variations in corporate profits.” I drew the left side of **Figure 1**. “Each block on the left holds one data point. Each month, the data in the flow graph advances by one block. The constants next to each branch represent multiplicative gain factors. In any given month, this machine sums the three values on the left and then divides by three, making the three-month running average. If I feed this machine a single impulse, what do you suppose comes out?”

Breathe wrote a “one” next to the box labeled X_N and zeros next to the other two boxes. He slowly worked out the details. “When the impulse first arrives, it loads into the first box. On subsequent samples, the impulse propagates to the middle box and finally to the bottom box. In all three cases, the sum equals one. After those three samples, the impulse falls out of the last block and disappears. Taking into account the scaling factor, the output as it crosses the dotted line must read $1/3$, $1/3$, and $1/3$, with zeros thereafter.”

“Perfectly done,” I said. “If I pump an unknown sequence through the machine, and all

you see is its output, can you restore the original sequence?”

Breathe thought a bit and said, “The first value is easy. It comes straight through your machine unchanged except for the scale factor of $1/3$, so just multiply it by three to find the answer. The second value is not too hard, either, because your machine hands me the sum of the first and second values. I already know the first, so I can subtract it from the sum to determine the second. After that point, I get confused.”

“That’s good,” I said, completing the right side of the diagram. “Because my machine on the left uses three storage blocks, the undo machine needs three, as well. Starting with all zeros on the right, see how the first sample comes right through? The undo machine stuffs that sample into a series of delay blocks exactly like the first machine. At each subsequent step, whatever the first machine adds, the undo machine subtracts. The recovered output perfectly tracks the original input.”

“Brilliant!” said Breathe. “How did you think of it?”

“I didn’t. It’s a standard IIR [infinite-impulse-response] filter. With enough delay blocks and suitable branch coefficients, you might use such a thing to undo an undesirable audio reverberation or fine-tune the response of a vintage phonograph recording. In my digital world, a similar structure forms the core of a decision-feedback equalizer. Using that device in a high-speed serial transceiver can undo the dispersive effect on signal transmission due to a long, lossy backplane trace. In all cases, the equalizer accomplishes the same thing: It simply undoes the effect of some LTI process” (**Reference 1**). **EDN**

REFERENCE

1 Bingham, John AC, *Theory and Practice of Modem Design*, John Wiley & Sons, 1988, ISBN 0-471-85108-6.

Howard Johnson, PhD, of Signal Consulting, frequently conducts technical workshops for digital engineers. E-mail him at howie03@sigcon.com.

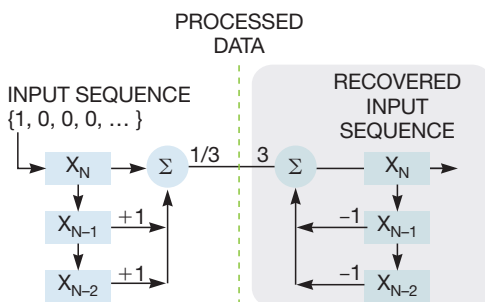

Figure 1 The recovery process subtracts what the first process adds.

2-Phase Synchronous Buck Controller Features Light Load Stage Shedding Mode, Active Voltage Positioning, Low R_{SENSE} and Remote V_{OUT} Sensing

Design Note 486

Charlie Zhao and Jian Li

Introduction

Today's computer, datacom, and telecom systems demand power supplies that are efficient, respond quickly to load transients and accurately regulate the voltage at the load. For example, load current can be measured by using the inductor DCR, thus eliminating the need for a dedicated sense resistor. Inductor DCR sensing increases efficiency—especially at heavy load—while reducing component cost and required board space. The LTC[®]3856 single-output 2-phase synchronous buck controller improves the accuracy of inductor DCR sensing by compensating for changes in DCR due to temperature.

DCR temperature compensation is just one of many performance enhancing features offered in the LTC3856. It also includes on-chip gate drivers, remote output volt-

age sensing, Stage Shedding™ mode for improved light load efficiency and adaptive voltage positioning for fast transient response. The LTC3856 can convert a wide input voltage range, 4.5V to 38V, to outputs from 0.6V to 5V. Despite the many features, the chip is small, available in 32-pin 5mm × 5mm QFN and 38-pin TSSOP packages.

High Efficiency, 2-Phase, 4.5V to 14V Input, 1.5V/50A Output Converter

Figure 1 shows a typical LTC3856 application in a 4.5V to 14V input, 1.5V/50A output converter. The LTC3856's two channels operate out-of-phase, which reduces the input RMS current ripple and thus the required input capacitance. Up to six LTC3856s can be paralleled for

LT, LT, LTC, LTM, Linear Technology, the Linear logo and Burst Mode are registered trademarks and Stage Shedding is a trademark of Linear Technology Corporation. All other trademarks are the property of their respective owners.

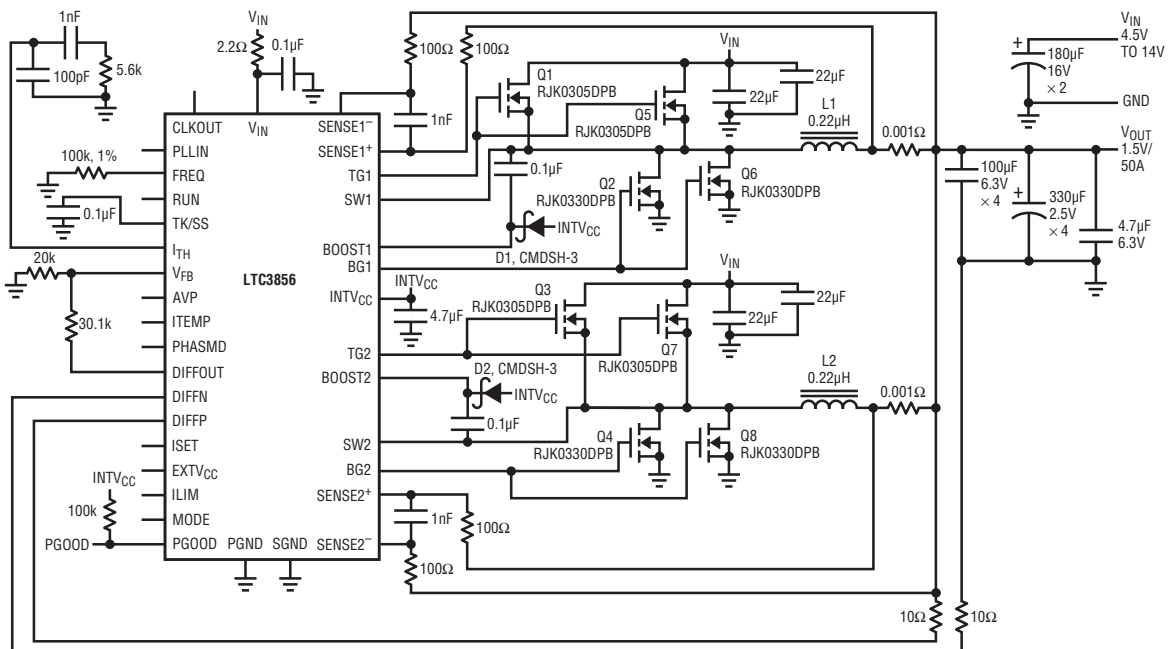

Figure 1. 1.5V/50A, 2-Phase Synchronous Buck Converter Featuring the LTC3856

up to 12-phase operation. The LTC3856 has a phase-locked loop (PLL) and can be synchronized to an input frequency between 250kHz and 770kHz. Due to its peak current-mode control architecture, the LTC3856 provides fast cycle-by-cycle dynamic current sharing plus tight DC current sharing, as shown in Figure 2.

Stage Shedding Mode

At light loads, the LTC3856 can be programmed to operate in one of three modes: Burst Mode® operation, forced continuous mode or Stage Shedding mode. With Stage Shedding mode, the LTC3856 can shut down one channel to reduce switching related loss which is the dominant loss at light loads. Stage Shedding mode is selected by simply tying the MODE pin to INTV_{CC}.

The efficiency improvements achieved by Stage Shedding mode are shown in Figure 3. Due to strong gate drivers and shorter dead-time, the LTC3856 can achieve 4% ~ 5% higher efficiency than the LTC3729, a comparable single-output, 2-phase controller, over the whole load range. With Stage Shedding mode, significant efficiency improvement is further achieved at light load. At 5% load, the efficiency is improved by 13%.

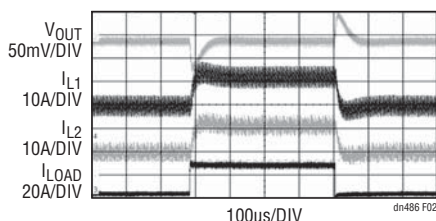

Figure 2. Load Transient and Current Sharing: V_{IN} = 12V, 25A to 50A Load Step

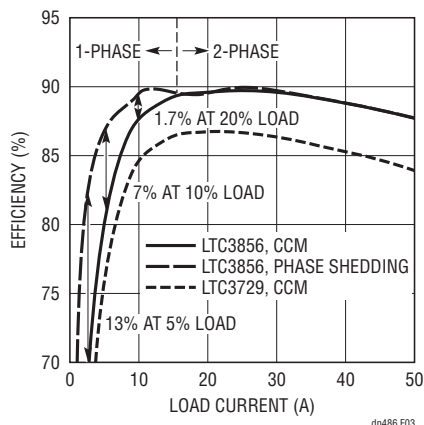

Figure 3. Efficiency Comparison: V_{IN} = 12V, V_O = 1.5V, F_{SW} = 400kHz, L = 220nH, R_{SENSE} = 1mΩ, Q_T = RJK0305DPB, Q_B = 2xRJK0330DPB

[Data Sheet Download](#)

www.linear.com

Current mode control allows the LTC3856 to transition smoothly from 2-phase to 1-phase operation and vice versa.

Active Voltage Positioning

User-selectable active voltage positioning (AVP) is another unique design feature of the LTC3856. AVP improves overall transient response and reduces required output capacitance by modifying the regulated output voltage depending on its current loading. With proper design, AVP can reduce load transient-induced peak-to-peak voltage spikes by 50%.

Inductor DCR Sensing Temperature Compensation

Although not used here, inductor DCR sensing offers a lossless method of sensing the load current. The problem is that the DCR of the inductor typically has a positive temperature coefficient, causing the effective current limit of the converter to change with inductor temperature. The LTC3856 can sense the inductor temperature with an NTC thermistor, thereby adjusting the current limit based on the temperature. The result is a constant current limit over a broad temperature range. This improves inductor DCR sensing reliability in high current applications.

Output Voltage Remote Sensing

For high output current, low voltage applications, board or wire interconnect resistance can cause a severe load regulation problem. To solve this problem, the LTC3856 includes a low offset, unity-gain, high bandwidth differential amplifier for true remote sensing. Common mode noise and ground loop disturbances can be rejected, and load regulation is greatly improved, especially when there are long trace runs between the load and the converter output.

Conclusion

The LTC3856 is a feature-rich single output, 2-phase synchronous step-down DC/DC controller. It achieves high efficiency in both heavy load and light load conditions, with temperature compensated DCR sensing and Stage Shedding mode or Burst Mode operation. AVP improves transient response even when the output capacitance is reduced. Remote sensing, a tight ±0.75% reference voltage accuracy over temperature, voltage tracking, strong on-chip drivers, multichip operation and external sync capability fill out its menu of features. The LTC3856 is ideal for high current applications and can meet the high standards of today's power supplies for telecom and datacom, industrial and computer applications.

For applications help,
call (408) 432-1900, Ext. 3258



BY PALLAB CHATTERJEE, CONTRIBUTING TECHNICAL EDITOR

Lithography for sub-20-nm processes

The recent San Francisco Bay Area Council IEEE Nanotechnology conference addressed the issue of nanoelectronics for sub-20-nm processes. The speakers—from Applied Materials, TSMC (Taiwan Semiconductor Manufacturing Co), Global Foundries, and Tabula—focused on a number of key challenges for tackling production on sub-20-nm designs. These challenges include lithography, materials, new devices, design architectures for interconnect, and 3-D chip stacking. The overriding challenge is lithography, which is the key to creating features at small device sizes.

Lithography has been facing continued throughput and resolution issues since the emergence of the 180-nm node. The current imaging equipment uses a laser light source that has a wavelength of 193 nm—the state of the art for stability and power for more than a decade. The only tool-based enhancement for the main optical path involved the change from dry optics, with air as the transmission medium, to immersion printing, which has a different index of refraction, sending the light beam through a liquid. The wave-

length of 193 nm means that simple projection onto a surface can pattern objects larger than the wavelength, and they will appear correct in shape and detail. The next-generation light source, EUV (extreme ultraviolet), features a laser with a wavelength of 13.5 nm (see a related figure at www.edn.com/110106nanotech).

To address features smaller than 13.5 nm, you must use interference patterns and other optical structures to help resolve the objects. These techniques include OPC (optical proximity correc-

tion) and SRAF (subresolution-assist-feature) creation and computational scaling of the lithographic source. The key is to reduce the k_1 factor in the minimum patterned pitch equation. Computational co-optimization methods include source optimization, focus scatter, mask-optimization software, and dose optimization. These computational approaches have allowed designers to reach the 40-nm node but are not sufficient to push to the next process stages.

New techniques, such as double, triple, and quadruple patterning, have shown positive results for creating the smaller geometries using available technologies. Double patterning is a standard method of printing for current 32/28-nm designs, and manufacturers have developed new equipment to help production facilities maintain their wafer throughput at levels comparable with those of single-patterning machines (Figure 1). To achieve even finer patterns, manufacturers use double patterning twice to create a quadrupling of structures.

EUV starts with a 13.5-nm light source and direct patterning. Using EUV with multiple patterning techniques would allow for high-quality patterning of the original image without the line-edge roughness. A major drawback, however, is that EUV must improve per-hour wafer throughput by at least a factor of 10 to keep up with the equipment in today's fabs.

Self-assembly, which targets use in sub-10-nm processes, suffers from the inability to create the self-assembly in complex patterns. For these applications, the leading technology employs the double-patterning technique using an EUV source. Another alternative uses a direct-write e-beam. To get the throughput, e-beam systems are shifting to the use of multi-beam systems—the approach of choice for high-end ASICs, which may have as many as 10,000 simultaneous beams writing one wafer. **EDN**

Pallab Chatterjee is on the IEEE Nanotechnology Council. You can reach him at pallabc@siliconmap.net.

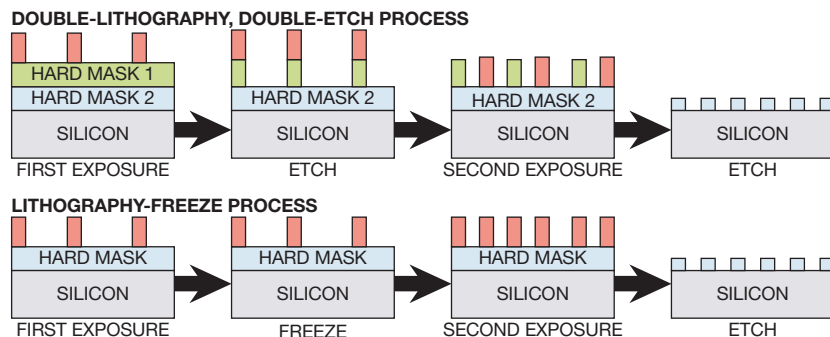

Figure 1 Double patterning is a standard method of printing for current 32/28-nm designs, and manufacturers have developed new equipment to help production facilities maintain their wafer throughput at levels comparable with those of single-patterning machines (courtesy SPIE).

CHARGE-RECOVERY CIRCUIT

MAXIMIZES PIEZOELECTRIC-ACTUATOR EFFICIENCY

BY MIKE AUGARTEN • ALLERGAN



THE NEVER-ENDING DRIVE FOR LOWER POWER AND LONGER BATTERY LIFE MAXIMIZES THE NEED FOR ACCURATE PIEZOELECTRIC ACTUATORS. A CHARGE-RECOVERY METHOD REDUCES PIEZOELECTRIC-ACTUATOR INPUT POWER BY EXPLOITING ENERGY TRANSFER BETWEEN AN INDUCTOR AND PIEZOELECTRIC-ACTUATOR CAPACITANCE.

Piezoelectric actuators are commonplace electronic devices, with examples including motors, fans, sound transducers, pumps, vibration controllers, deflection plates, position stabilizers, and active optics. In general, these piezoelectric devices operate at less than 50 kHz and below the piezoelectric actuator's resonant frequency, with power dissipation of less than a few watts and primary capacitance of less than a few hundred nanofarads. Equivalent circuits of piezoelectric actuators are useful for simulation models. When a periodic voltage drives the equivalent circuit, it can become a complex combination of resistance, inductance, and capacitance. However, a periodic voltage source can have a frequency lower than the resonant frequency of the piezoelectric actuator. When this voltage source drives the circuit, you can simplify the equivalent-circuit model for the device to one capacitor (references 1 and 2).

In this scenario, you can employ the familiar expression for the power dissipation of a capacitor with an applied periodic voltage: $P=CV^2F$, where P is power, C is capacitance, V is voltage, and F is the driving frequency. The

product of the capacitance, the voltage squared, and the driving frequency determines power. To minimize power, your first thought might be to reduce any of these parameters. Lowering the voltage would be the most bene-

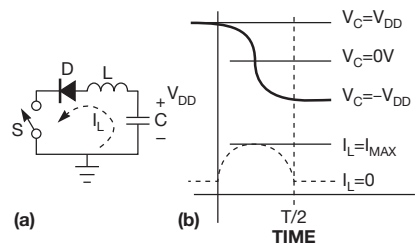

Figure 1 Assume for a time less than zero the capacitance is initially charged to the drain-to-drain voltage, V_{DD} , and no current flows in the circuit because the switch is open. At a time of zero, the switch closes, and current starts flowing from the capacitor in the direction of the arrow (a). The cycle would continue with the current in the opposite direction because the capacitor has charged to $-V_{DD}$. However, the diode appears as an ideal open circuit, and the energy transfer is complete (b).

ficial approach because power relates to the voltage squared. Unfortunately, you often cannot reduce the voltage; the piezoelectric capacitance, which relates to the actuator's size; and the driving

frequency without adversely affecting proper operation. However, because the piezoelectric actuator's capacitance is essentially an energy-storage device, another possibility is to recover this energy and thereby reduce power.

Power dissipation due to charging and discharging the piezoelectric capacitance can be significant. The charging of an initially discharged capacitance from a constant voltage source requires a total energy, which the following equation defines: $E=C \times V^2$. After fully charging the capacitor, the energy stored in the capacitor is half the total energy because the other half of the energy dissipates in the circuit resistance. After discharging, the capacitor's stored energy fully dissipates in the circuit resistance. Consequently, most of the energy in the circuit dissipates as heat and not as the useful work of piezoelectric-actuator motion.

Ideally, you would be able to recover rather than waste as heat the energy stored in the piezoelectric actuator's capacitance and thus lower the circuit's required input power. You can use capacitors or inductors as passive energy-storage devices for energy recovery. For example, the charge stored in the piezoelectric capacitance could transfer to a second recovery capacitor during discharge of the piezoelectric capacitance. Then, on the next charge cycle of the piezoelectric capacitance, the recovery capacitor would provide its stored energy back to the circuit. However, you can recover only 50% of the piezoelectric capacitance charge when the recovery storage element is a capaci-

AT A GLANCE

■ Piezoelectric actuators are becoming increasingly common in applications ranging from consumer to industrial to medical devices.

■ An energy-recovery circuit can minimize power consumption and extend battery life.

■ A reduction in the number of cooling components and a simplified power supply balance the additional costs of the energy-recovery circuit components.

tor (Reference 3). On the other hand, the resonance between an inductor and a capacitor provides a way to theoretically recover the complete energy of the piezoelectric capacitance.

Consider the circuit of Figure 1a with diode D, inductor L, capacitor C, and switch S. Assume for a time less than zero, the capacitance is initially charged to the drain-to-drain voltage, V_{DD} , and no current flows in the circuit because the switch is open. At a time of zero, the switch closes, and current starts flowing from the capacitor in the direction of the arrow. Under these conditions, the diode is an ideal short circuit. Current I_L 's flowing induces a magnetic field in the inductor, which continues until the capacitor completely discharges at a V_C of 0V. Once the capacitor completely discharges, the current in the inductor ramps down as the magnetic field of the inductor collapses. In the process, energy from the magnetic field transfers back to the

capacitor. This process continues until the magnetic field completely dissipates and the capacitor charges to the negative drain-to-drain voltage, $-V_{DD}$. At this point, the cycle would continue with the current in the opposite direction because the capacitor has charged to $-V_{DD}$. However, the diode appears as an ideal open circuit, and the energy transfer is complete. Figure 1b shows the complete cycle for the inductor current and capacitor voltage.

You can express the period of current flow in the circuit as $T/2=1/(2 \times F)=\pi \times (L \times C)^{1/2}$. The diode automatically opens the circuit when the full energy transfer to the capacitor has occurred. This approach avoids the need for accurate timing to turn off the switch at precisely $T/2$ to get maximum energy recovery.

This explanation assumes an ideal diode and a lossless circuit. In reality, losses will occur due to resistance in the components, and the circuit may be using a nonideal diode. Because the full voltage swing is necessary, you use the power supply to force and hold the final voltage on the capacitance. The less loss the circuit has, the less power it will require from the power supply.

You can apply the principal of energy recovery to a practical circuit for charging and discharging the piezoelectric capacitance (Figure 2). In this case, you use opposite diode orientations and a shared inductor to charge the piezoelectric capacitance to a positive or a negative voltage. The inductance value must be large enough so that it can ramp to the full current from the piezo-

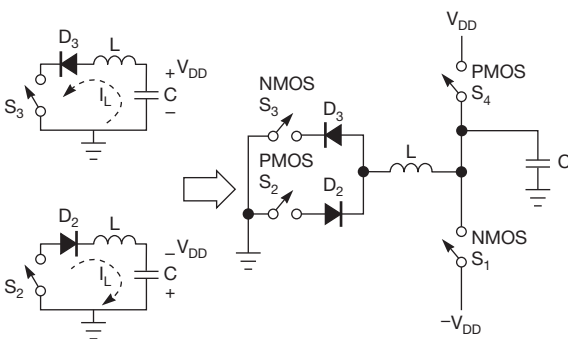

Figure 2 You can apply the principal of energy recovery to a practical circuit for charging and discharging the piezoelectric capacitance.

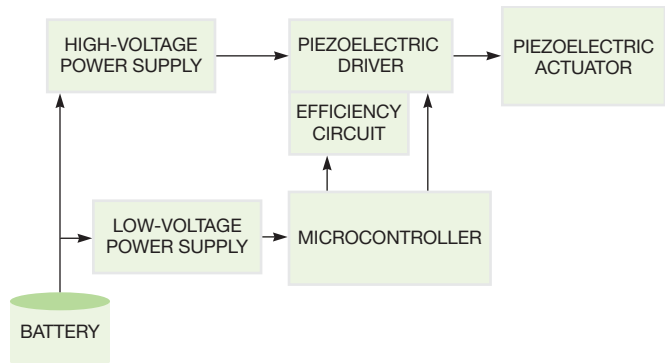

Figure 3 A low-voltage power supply regulates the battery to a voltage the circuit's microcontroller requires. The high-voltage supply generates the electric field the piezoelectric actuator requires and is implemented with a boost-topology switching regulator.

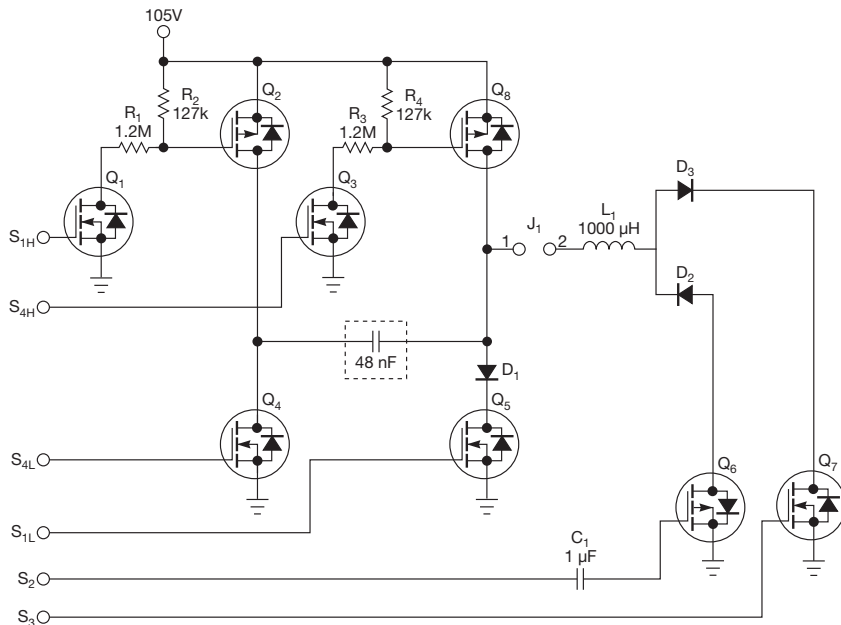

Figure 4 A driver with energy recovery for the piezoelectric actuator incorporates an H-bridge driver along with the energy-recovery components in which FETs now represent the switches. The H-bridge supports the use of a single high-voltage source to oppositely polarize the piezoelectric actuator during each half of the operating period.

electric capacitance without saturating and small enough that the time of $T/2$ from $T/2 = 1/(2 \times F) = \pi \times (L \times C)^{1/2}$ is less than half the piezoelectric actuator's operating period. The switches are models for a FET. Assume that all the switches are open and that the piezoelectric capacitance is discharged. You can then use the repetitive sequence in **Table 1** to drive the piezoelectric actuator with energy recovery.

BUILDING BLOCKS

A battery-operated piezoelectric-actuator circuit requires certain functional blocks (**Figure 3**). A low-voltage power supply regulates the battery to a voltage the circuit's microcontroller requires. The low-voltage supply can be a linear regulator or a buck or boost switching regulator, depending on the battery voltage. The high-voltage supply generates the electric field the piezoelectric actuator requires and is implemented with a boost-topology switching regulator. To be consistent with power efficiency, the microcontroller should be a low-power device with the principal requirements of generating the piezoelectric actuator's operating frequency and providing control signals for the actuator's driver and efficiency circuit.

Focusing in on the piezoelectric driv-

er and efficiency circuit, the circuit in **Figure 4** incorporates an H-bridge driver along with the energy-recovery components in which FETs now represent the switches. The H-bridge driver supports the use of a high-voltage source to oppositely polarize the piezoelectric actuator during each half of the operating period. When Q_8 and Q_4 are on, they enable a current path representing S_4 ; when Q_2 and Q_5 are on, they enable a current path representing S_1 .

To allow interfacing between the high voltage associated with Q_2 and the low voltage output of the microcontroller, Q_1 , R_1 , and R_2 act as a level translator. Q_8 has a similar circuit. Diode D_1 prevents the piezoelectric-actuator capacitance from discharging through Q_3 instead of the intended path through L_1 , D_2 , and Q_6 . Capacitor C_1 translates a low-going signal on S_2 to a negative voltage to properly turn on Q_6 . The microcontroller orchestrates the control for each of the FET-gate signals to produce a conveyed sequence (**Figure 5**). Jumper J_1 facilitates comparison of the circuit with and without energy recovery. With J_1 , the circuit incorporates energy recovery; without J_1 , there is no energy-recovery circuitry.

A prototype circuit represents the piezoelectric-actuator driver with ener-

gy recovery. The prototype's measured piezoelectric static capacitance is 48 nF, which a square wave with a 10-msec period drives, and effective drive voltage is 210V. Testers substituted a power supply for a battery to provide a consistent input voltage to the prototype circuit. **Table 2** shows the results of measuring the rms (root/mean/square) current into the circuit for the piezoelectric driver both with and without energy recovery.

As you would expect, the circuit with energy recovery requires less input power. After accounting for the logic components that require equivalent power in either circuit, such as the microcontroller and power-supply-conversion circuits, the energy-recovery topology still requires some residual power for the piezoelectric-actuator driver. This result is due to resistive losses in the associated diodes, inductors, and FETs and the dynamic variation in piezoelectric capacitance (**Reference 4**). The area and cost of the circuit with energy recovery increased due to the additional components necessary for implementing the energy-recovery circuit.

GAIN WITH LITTLE PAIN

In theory, with ideal components it should be possible to achieve 100% efficiency for a piezoelectric-actuator driver. However, with nonideal, typical components, the actual circuit measurement is closer to 63% power efficiency, thus establishing a practical target for expected power efficiency. To achieve optimum efficiency, you should select diodes, inductors, and FETs with minimal resistance.

Further, the dynamic capacitance can be significantly larger than the static capacitance of the piezoelectric actuator, which requires a larger

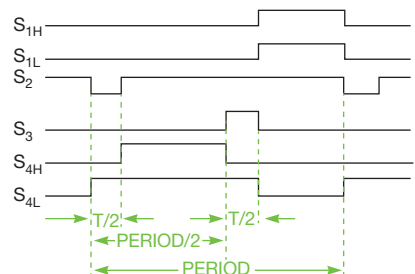

Figure 5 The microcontroller generates the control signals for each of the FET gates that drive the H-bridge.

TABLE 1 CONTROL SEQUENCES OF SWITCHES

State	Description
1	All switches open; S_2 then closes for at least $T/2$; the initial closure has no effect on the capacitor; every subsequent closure changes voltage across the piezoelectric actuator's capacitance from $-V_{DD}$ to $+V_{DD}$ as current flows from ground through S_2 , D_2 , and L to charge C
2	All switches open; S_4 then closes for the remainder of the time that the piezoelectric-actuator-driver waveform is at V_{DD} ; on the initial closure, the power supply fully charges C ; every subsequent closure uses a small amount of power from the V_{DD} power supply to compensate for any losses in the charge-recovery circuit and leakage in C
3	All switches open; S_3 then closes for at least $T/2$; the piezoelectric actuator's capacitance charges from $+V_{DD}$ to $-V_{DD}$ as current flows from C through L , D_3 , and S_3 to ground
4	All switches open; S_1 then closes for the remainder of the time that the piezoelectric-actuator-driver waveform is at $-V_{DD}$; a small amount of power from the $-V_{DD}$ power supply is necessary to compensate for any losses in the charge-recovery circuit and leakage in C

TABLE 2 COMPARISON OF PIEZOELECTRIC-ACTUATOR CIRCUITS

Piezoelectric-actuator-drive topology	Logic power (mW)	Driver power (mW)	Area (in. ²)	Component cost
Without recovery	32	276.8	1.79	\$39
With recovery	32	101.5	3.02	\$54

energy-recovery inductor than calculating $T/2=1/(2 \times f)=\pi \times (L \times C)^{1/2}$ using just piezoelectric-actuator static capacitance. Therefore, it is a good idea to measure the piezoelectric actuator's effective dynamic capacitance in the circuit and verify that the energy-recovery inductor is the appropriate value for the measured capacitance.

Using energy recovery to reduce a piezoelectric-driver circuit's power isn't free. The price for energy recovery is additional components with added cost and space, more output pins from the system microcontroller, and extra coding for control of the circuit. However, you can easily justify the cost of implementing energy recovery when you weigh it against the potential reduction in system-cooling requirements and simplified power-supply design. Careful selection of components with a focus on size, cost, and integration can further tilt the balance in favor of implementing energy recovery. **EDN**

REFERENCES

1 Morgan Technical Ceramics, "Piezo Ceramic Tutorials: Circuit Considerations," 2009, <http://bit.ly/e4Xkd6>.

2 Robinson, Sam, "Driving Piezoelectric Actuators," *Power Electronics Technology*, April 2006, pg 40, <http://bit.ly/eM50sv>.

3 Campolo, Domenico; Metin Sitti; and Ronald S Fearing, "Efficient Charge Recovery Method for Driving Piezoelectric Actuators with Quasi-Square Waves," *IEEE Transactions On Ultrasonics, Ferroelectrics, and Frequency Control*, January 2003, Volume 50, No. 1, <http://bit.ly/fL0yaP>.

4 Jordan, T; Z Ounaies; J Tripp; and P Tchong, "Electrical Properties and Power Considerations of a Piezoelectric Actuator," *NASA/CR-2000-209861 Icase Report No. 2000-8*, February 2000, <http://bit.ly/eywzd>.

AUTHOR'S BIOGRAPHY

Mike Augarten has more than two decades of hands-on design engineering and management experience in chip design, high-speed PCBs, software projects, and complex systems. His career has spanned challenges from start-ups to large companies with international exposure, and he is currently involved in product development in the medical-device industry. You can learn more at www.mike-augarten.com.



Introducing the easiest way to get your wireless product off the ground.

WIN
one of three snowboard packages!

Enter the Anaren "BIG AIR" sweepstakes for your chance to win a snowboard gift card worth \$599!* Go to www.bigairsweeps.com



Say hello to the industry's easiest, most elegant, and cost-effective RF implementation: AIR modules!

- > Surface-mount module makes your product 'wireless' in record time – based on TI's CC1101 or CC2500 chips!
- > Choose 433MHz, 800MHz, 900MHz, or 2.4GHz models – all with tiny, common footprints
- > Virtually no RF engineering experience required
- > FCC, Industry Canada/RSS, ETSI compliant (or pending) – no additional "Intentional Radiator" certifications required

To learn more, order samples, or obtain a quote – email AIR@anaren.com or contact one of these distributors.



*NO PURCHASE NECESSARY TO ENTER OR WIN. PURCHASE OR PAYMENT OF ANY KIND WILL NOT INCREASE YOUR CHANCES OF WINNING. Sweepstakes will begin at 12:00 AM ET on January 1, 2011 and end at 11:59 PM ET on March 15, 2011. Open to all legal residents in the United States and Canada (excluding Quebec) that are 18 years of age or older as of 1/1/11 that are business owners or employees of businesses that design and/or manufacture electronic products/equipment. THIS SWEEPSTAKES IS NOT OPEN TO THE GENERAL PUBLIC. For Official Rules, which include entry methods, prize description, and complete details, visit www.bigairsweeps.com. Sponsor: Anaren, Inc. Void where prohibited.

Anaren®
What'll we think of next?®

800-411-6596 > www.anaren.com

In Europe, call 44-2392-232392
ISO 9001 certified
Visa/MasterCard accepted
(except in Europe)



IC VENDORS SEEK **GREEN** **APPLICATIONS**

BY RICK NELSON • EDITOR-IN-CHIEF



Semiconductor vendors introduced a slew of chips and components toward the end of 2010. Their product introductions, many of which occurred during the Electronica show in November in Munich, suggest trends that will carry on through 2011: the increasing power of multicore processors, a proliferation of sensors and sensor-interface chips, increasingly innovative human-to-machine-interface devices, compact optical and wireless transceiver devices, low-power LEDs and drivers, and even sophisticated circuit-protection devices (see **sidebar** “Circuit-protection devices complement ‘green’ ICs”).

If you could use one adjective to describe most of these new products, that word would be “efficient,” with the chip vendors looking to enable increasing efficiency in applications including telecommunications, automotive electronics, mobile consumer devices, consumer appliances, medical electronics, and solar and wind farms.

At Electronica, STMicroelectronics Chief Executive Officer Carlo Bozotti cited “green” technologies as among the key trends that his company plans to harness for continued semiconductor success in the future (see **sidebar** “Semiconductor executives assess where we’re going”). Products his company highlighted at the show included the high-performance, low-power MP45DT01 digital-output stereo microphone. The MEMS (microelectromechanical-system) device targets audio applications across a range of market segments, including cell phones, portable media players, games, digital cameras, security systems, learning devices, and hearing aids. The microphone uses sensor technology from Omron that is inherently less susceptible to mechanical vibration, temperature variations, and EMI (electromagnetic interference).

Other devices from STMicro addressing low-power applications include extensions of its STM8L EnergyLite ultra-low-power microcontroller family, with three new variants—the STM8L151, the STM8L152, and the STM8L162—each offering 64 kbytes of flash memory, effectively doubling the maximum program/data memory available to developers using the 8-bit STM8L family. The STM8L152 adds an enhanced LCD controller that supports larger segments, and the STM8L162 is the first device in a new line featuring on-chip 128-bit AES (Advanced Encryption System) encryption, according to the company.

In addition, STMicro highlighted its SPV1001, which contains a low-loss pow-

er switch and a precision controller and directly replaces the bypass diodes that prevent hot-spot effects in solar panels. The SPV1001 saves the energy that the diodes normally lose.

STMicro augmented its sensor portfolio with a new automotive-grade three-axis low-g accelerometer. Combining low power consumption and a small footprint with high precision and robust performance, the accelerometer targets automotive applications, including vehicle tracking, event recording, abuse monitoring, and dead-reckoning for enhanced navigation capabilities. STMicro’s AIS328DQ senses acceleration along all three axes and converts the motion and tilt information into a high-resolution digital signal that it transmits to a microcontroller through a standard SPI (serial-peripheral interface) or I²C (inter-integrated-circuit) interface.

The company also introduced the low-power S-Touch FingerTip touchscreen controller for smartphones. The device includes noise cancellation to support on-cell LCD technology without requiring a ground-shielding layer between the display and the touch sensor, enabling smartphones to have thinner touchscreen-LCD modules. In addition, STMicro released details of a patented high-efficiency circuit and dedicated optimized power components for use in boost or buck converters in switched-mode power supplies for computers and telecom equipment. The company’s new design, BC2 (back-current circuit), now allows the use of competitively priced silicon diodes in place of expensive SiC (silicon-carbide) devices. STMicro also announced a family of six silicon-based rectifiers and free-wheel diodes for BC2 applications.

ENABLING INCREMENTAL GAINS

Fairchild was also touting efficiency and green applications. Mark Thompson,

WITH DEVICES RANGING FROM DSPs TO HALL-EFFECT SENSORS, SEMICONDUCTOR MANUFACTURERS ARE LOOKING TO IMPROVE EFFICIENCY IN APPLICATIONS RANGING FROM TELECOMMUNICATIONS TO AUTOMOTIVE ELECTRONICS.

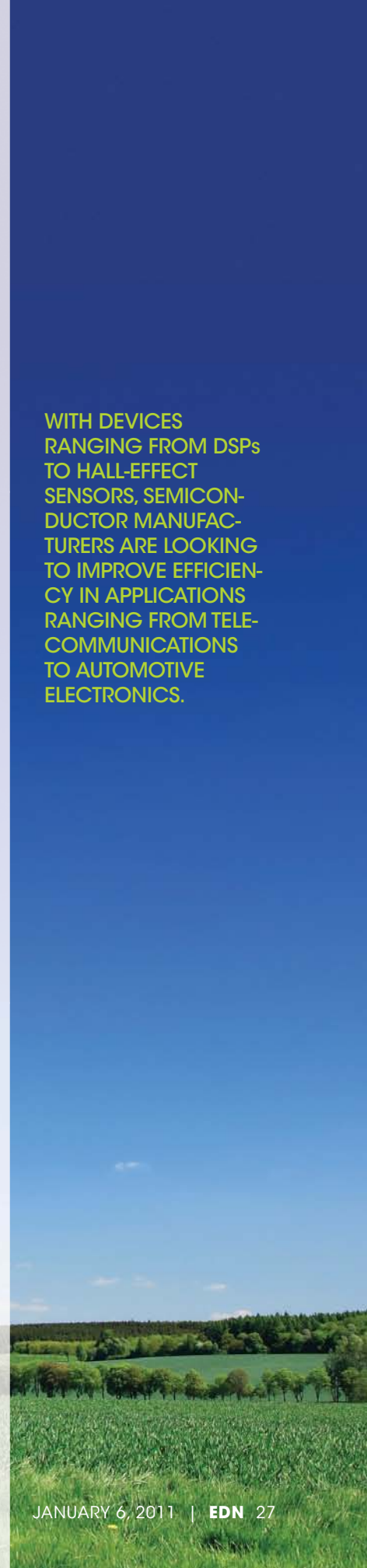



Fairchild's president, chief executive officer, and chairman, at an Electronica press conference suggested that efficiency is a key concern of the company's power-conversion, industrial, and automotive group and the mobile, consumer, and communications group. Efficiency, Thompson said, was once a concern only of engineers; today, it's a concern of consumers and governments, which often mandate efficiency standards.

Chip makers such as Fairchild are not necessarily targeting the huge efficiency gains that engineers could achieve with breakthrough technologies such as all-electric vehicles. Rather, they are often looking to enable incremental gains that result in slow but steady improvements. Commenting on the automotive segment, Thompson suggested that gains in efficiency will come with the increasing adoption of brushless dc motors, which is also occurring in consumer appliances. For the next decade, Thompson expects, hybrid and all-electric vehicles will remain a small part of the market, with gains in fuel efficiency coming incrementally as auto manufacturers replace hydraulic and other parasitic loads in, for example, power-steering mechanisms and water pumps with higher-efficiency Fairchild power-module-based alternatives. In other areas, the company is looking to improve the sleep-mode efficiency of power supplies and is pursuing continual improvements in smartphones, with the innovations Fairchild provides decoupled from the big cores the manufacturers are using.

The pursuit of such applications has required some changes in Fairchild's business approach, Thompson said, explaining that, as its standard-product emphasis has dwindled, the company

AT A GLANCE

- Product introductions at Electronica suggest trends that will continue through 2011.
- Chip vendors look to increased efficiency in applications involving telecommunications, automotive electronics, mobile consumer devices, consumer appliances, medical electronics, and solar and wind farms.
- Efficiency, once a concern only of engineers, is now a concern of consumers and governments.
- Vendors often look to enable incremental gains that result in slow but steady improvements.
- A new base-station SOC with programmable-DSP cores enables a software-defined radio that boosts spectral efficiency.
- Teamwork yields a MEMS (microelectromechanical-system) microphone, a magnetic-encoder family, and a chip set for Atom processors.
- Fuel-saving features, such as start/stop, can have unwanted consequences, presenting IC vendors with opportunities.

is turning to a distribution-centered approach in favor of more emphasis on a direct sales force. The aim, he added, is not to target a particular part, such as a MOSFET, but rather an application, such as solar. Toward that end, Fairchild focuses on a deliberately diversified but not too diverse application spectrum. Industrial accounts for 30% of the company's revenue, consumer for 25%, computing for 23%, handsets and communications for 16%, and automotive for 5%. Such a mix accounts for seasonal and other variations in each segment.

Fairchild introduced the FAN9612 BCM (boundary-conduction-mode) interleaving PFC (power-factor-correction) controller (Figure 1), which provides more than 96% power-conversion effi-

ciency for ac/dc power supplies. Applications include power supplies for digital TVs, desktop and entry-level server computers, front-end telecom systems, and industrial-power systems operating at 100 to 1000W. The company reports that an interleaving technique boosts the device's maximum output to 1000W from the typical 300W level of lower-cost BCM PFC converters. Interleaving also enables a reduction of the input-filter size, reducing board space by as much as 10%.

Other new devices from Fairchild include the 2.5A FOD3120 and 1A FOD3150 output-current gate-drive optocouplers for use in solar inverters, motor drives, and induction-heating applications; 2.8 to 36V AccuPower integrated current-limiting load switches, which provide full protection to systems and loads that may encounter large current conditions; and the FAN5400 family of USB-compliant, lithium-ion switching chargers with USB OTG (On-The-Go) capabilities.

POWER CONVERTERS

Micrel focused on power ICs at Electronica, as well, including the MIC26xxx SuperSwitcher II fully integrated power-converter line, which comprises three dc/dc buck regulators featuring the company's proprietary Hyper Speed Control architecture. The MIC26400, MIC26600, and MIC26950 devices operate with an input supply voltage of 4.5 to 26V and deliver an output current of 5, 7, and 12A, respectively. Micrel also highlighted its MIC2176-1/2/3 family of constant-frequency, synchronous buck controllers featuring a digitally modified adaptive on-time control architecture. The MIC2176 family operates over an input supply range of 4.5 to 75V and can supply as much as 15A of output current. The output voltage is adjustable to 0.8V with a guaranteed accuracy of $\pm 1\%$, and the device operates at a constant switching frequency of 100, 200, and 300 kHz. Micrel's Hyper Speed Control architecture allows for fast transient response; reduces output capacitance; and enables high-input-voltage, low-output-voltage operation. The controller targets distributed-power systems; networking/telecom infrastructure; and printer-, scanner-, graphics-, and video-card applications.

For portable-system applications, Mi-

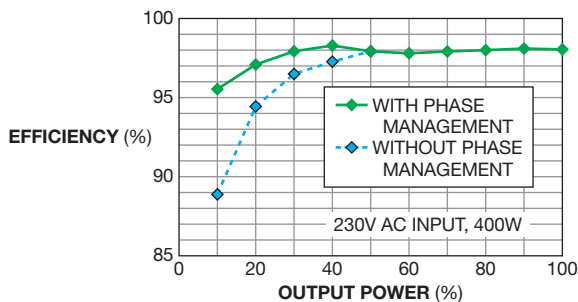

Figure 1 The Fairchild FAN9612 BCM interleaving PFC controller employs phase management to achieve high efficiency even at low output power levels.

APEC® 2011

March 6–10, 2011

Fort Worth Convention Center
Fort Worth, TX

THE PREMIER
GLOBAL EVENT
IN POWER
ELECTRONICS™

Visit the Apec 2011
web site for the latest
information!

www.apec-conf.org

SPONSORED BY



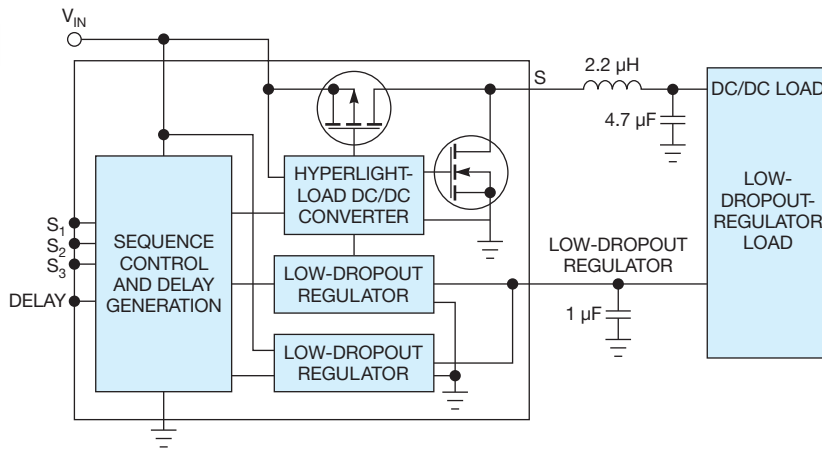

Figure 2 Micrel's MIC23060 portable power-management IC integrates a high-efficiency dc/dc converter with the company's HyperLight Load technology and a post-regulating, low-voltage-capable low-dropout regulator.

crel presented the MIC23060, an efficient, portable power-management IC that integrates a high-efficiency dc/dc converter with the company's HyperLight Load technology and a postregulating, low-voltage-capable low-dropout regulator (**Figure 2**). The device includes a flexible sequencing feature that

allows users to configure it for many of the market's latest processors. Targeted applications include mobile phones, PDAs, digital cameras, and DSP power supplies. Also on display was the MIC23153, the highest-output-current device in the HyperLight Load family of synchronous step-down regulators.

The MIC23153 implements a patented architecture that delivers a high-efficiency light load for portable products and green-home and -office appliances. The MIC23153 features internal MOSFETs that can deliver 2A output current and that consume just 23 μA of quiescent current in a 2.5x2.5-mm thin-MLF package. The MIC23153 achieves as much as 93% peak efficiency and 87% efficiency under a 1-mA load. In addition, the MIC23153 offers an adjustable soft start to minimize battery-transient loading.

Micrel's LED-related products include the MIC3201/02/03 family, which can drive as many as four 1A HB LEDs (high-brightness light-emitting diodes) in series at more than 90% efficiency with $\pm 5\%$ current accuracy from input voltages of 4.5 to 20V. With its hysteretic-control architecture and high-side current-sense scheme, the MIC3201 can provide constant current with changes in input voltage and output load. The MIC3201's operating frequency is adjustable to 1 MHz to allow

CIRCUIT-PROTECTION DEVICES COMPLEMENT "GREEN" ICs

The innovations that vendors presented at Electronica 2010 ran the gamut from ICs and components to test-and-measurement equipment. Manufacturers presented circuit-protection devices that might, at first glance, seem important yet less eye-catching than, for example, multicore DSPs. Nevertheless, Tyco Electronics presented a couple of such devices worth a closer look.

Low-power devices often find their way into battery-powered products, which require protection from overcurrent situations that could damage the battery and lead to safety problems. Tyco is addressing such applications with an MHP (metal-hybrid-polymetric-positive-temperature-coefficient) device that protects lithium-ion batteries in high-power applications, providing bimetal protection with built-in arc-suppression technology. It addresses applications such as those involving consumer power tools in which a drill bit gets stuck, resulting in a potentially damaging overcurrent condition.

The device serves battery applications at ratings higher than 30V dc and 30A; it includes a bimetal device, which opens and closes as fault conditions occur and clear, in parallel with an MHP device that suppresses

arcing when the bimetal device opens, thereby avoiding the likelihood that the bimetal contacts can weld shut. You can install the compact device in a battery pack.

Tyco also introduced an RTP (reflowable-thermal-protector) device (**Figure A**) that offers simplified thermal protection in an SMD (surface-mount-device) package.



Figure A The RTP device offers simplified thermal protection in an SMD package. It provides protection due to copper-loss heating in resistive faults, such as a failed FET in resistive mode, in which overcurrent is not a factor.

Competitive devices can't withstand reflow temperatures; after all, melting is the operational mechanism by which such devices work. However, Tyco's new product, suitable for automotive and industrial operations, is a robust, vibration-insensitive, dc-rated, lead-free device that can withstand up to three 260°C reflow passes without opening. During reflow, a fuselike support mechanism holds the circuit-protection mechanism in place, even

though its solder connection melts. On initial power-up, the support mechanism opens, arming the device. Subsequently, the device opens if the junction temperature exceeds 200°C. Note that the device is a temperature-sensing—not a current-sensing—device. It provides protection due to copper-loss heating in resistive faults, such as a failed FET in resistive mode, in which overcurrent is not a factor.

flexibility in the design. The MIC3201 features a dedicated PWM (pulse-width-modulated) dimming pin, an enable pin for very-low-power shutdown, overtemperature protection, and undervoltage lockout. The MIC3201 has an internal power switch and requires no external compensation. In addition to enhanced power-driving capability and reliability, the MIC3201 comes in an exposed-pad SOIC-8L package.

Micrel also highlighted the MIC28xx series of high-efficiency white-LED drivers to drive multiple LEDs and extend battery life for portable display backlighting and keypad backlighting in mobile devices. The MIC2842A architecture boosts efficiency by avoiding the switching losses that occur in traditional charge pumps or inductive boost circuits. The MIC2843A provides six linear drivers, which maintain constant current for as many as six white LEDs. With a typical dropout voltage of 40 mV at 20 mA, the MIC28xx devices allow the battery to directly drive the LEDs, eliminating the switching noise and losses that occur with the use of boost circuitry.

Low-power Ethernet products were also on display. Micrel's KSZ8051/8031 family of low-power, small-package, single-port 10/100-Gbps PHY transceivers provides the MII (media-independent interface) or RMII (reduced media-independent interface) to transmit and receive data over standard Category 5 UTP (unshielded-twisted-pair) cable or fiber. Micrel based the device on its enhanced mixed-signal design, which halves power consumption compared with the previous generation. The devices feature high integration, including on-chip termination and an integrated regulator; reduced system cost; and simplified system design. Micrel also exhibited the KSZ8873/KSZ8863 series of highly integrated, three-port switch-on-chip ICs, which, according to the company, offer the industry's smallest footprint.

LOW-POWER CONVERTERS

Linear Technology Corp addressed green applications with power-management as well as data-converter chips. It introduced three families of low-power, 16-bit, 25M- to 125M-sample/sec ADCs that dissipate approximately half the power of competing 16-bit prod-

ucts. The single-channel LTC2165 and two-channel LTC2185 simultaneously sampling parallel ADCs, offer a choice of full-rate CMOS or DDR CMOS/LVDS (low-voltage-differential-signaling) digital outputs with programmable digital output timing, programmable LVDS output current, and optional LVDS output termination. The LTC2195 family includes two-channel, simultaneously sampling ADCs with serial LVDS outputs. The low-power, 16-bit ADCs target applications such as handheld test instruments, radar/LIDAR systems, portable medical-imaging systems, PET and SPECT scanners, smart-antenna systems, and low-power communications systems.

For power applications, Linear announced the LTC3112 synchronous buck-boost converter (**Figure 3**), which delivers as much as 2.5A of output current from a range of power sources, including single- or multiple-cell batteries, supercapacitor stacks, and wall adapters. Its 2.7 to 15V input range and 2.5 to 14V output range provide a regulated output with inputs higher than, lower than, or equal to the regulated output. The LTC3112 incorporates a low-noise buck-boost topology that provides a continuous, jitter-free transition between buck and boost modes. You can synchronize the LTC3112's default 750-kHz switching frequency to an external 300-kHz to 1.5-MHz clock.

Also for power applications, Linear introduced the LT3692 monolithic, dual-output, step-down switching regulator that can deliver as much as 3.5A of continuous output current from each channel; the LTM4628 μ Module regulator, which contains two step-down 8A dc/dc-converter circuits with the induc-

tors, MOSFETs, and other necessary components in a 15x15x4.32-mm LGA package; and the six-output LTM8008 six-output dc/dc μ Module regulator, which operates from -40 to +150°C and includes a 3 to 72V input SEPIC and six linear regulators in a 15x15x2.82-mm LGA package.

SPECTRAL EFFICIENCY

Texas Instruments chose Electronica to reaffirm its commitment to the high-performance embedded-processing market with the introduction of the TMS320C66x fixed- and floating-point DSP cores plus four scalable C667x multicore DSP devices, which can help enable green initiatives, such as the smart grid. The company built the new DSPs with multiple 1.25-GHz DSP cores. According to Ramesh Kumar, TI's worldwide business manager for multicore and media-infrastructure DSP, they are the industry's first 10-GHz DSPs with 320 GMACS (billion multiply/accumulate operations per second) and 160 Gflops (billion floating-point operations per second) of performance on a device. TI based the C667x DSP family on the company's new KeyStone multicore architecture, which maximizes the throughput of on-chip data flows and eliminates the possibility of bottlenecks, so that developers can fully use the processing power of the DSP cores.

TI is also introducing a wireless-base-station SOC with 4G-class performance. The company built the device as a wireless data engine from its inception; the new TMS320TCI6616 base-station SOC employs the new TMS320C66x DSPs and KeyStone multicore architecture. The TCI6616 also performs both fixed- and floating-point math.

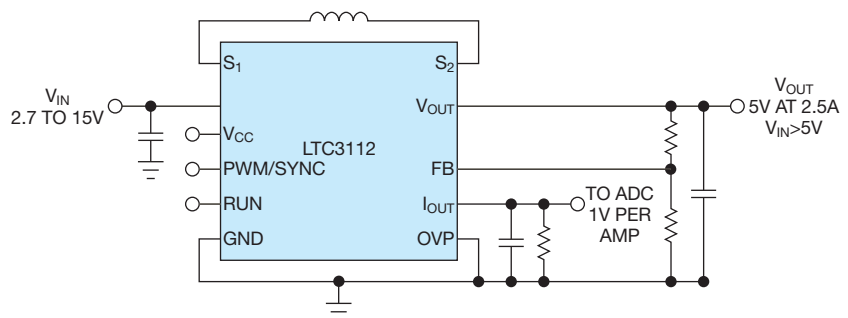

Figure 3 The LTC3112 synchronous buck-boost converter delivers as much as 2.5A of output current from a range of power sources, including single- or multiple-cell batteries, supercapacitor stacks, and wall adapters.



The C667x DSP family includes three pin-compatible multicore DSPs in two-, four-, and eight-core versions, the TMS320C6672, TMS320C6674, and TMS320C6678, respectively, as well as a four-core communications SOC, the TMS320C6670. Using TI's C667x multicore DSPs, infrastructure developers can now more easily design integrated, software-upgradable, power- and cost-efficient platforms in mission-critical markets involving public safety and defense, medical and high-end imaging, test and automation, high-performance computing, core networking, and smart grids.

Kumar singles out advanced imaging products for wafer inspection, LCD inspection, solar-cell inspection, smart cameras for factory automation, ultrasound systems, and industrial microscopes as key targets for the new multicore devices. In the test-and-measurement area, he highlights vector signal analyzers, spectrum analyzers, vector signal generators, base-station analyzers, audio/video-quality testers, impairment generators, mobile-phone service testers, and traffic generators and analyzers as instruments that could employ the new multicore DSPs. TI also offers the MC-SDK (multicore-software-developer kit) and a suite of multicore tools, as well as an ecosystem of software and hardware partners. The new C667x multicore DSPs are also software-compatible with TI's C6000 DSPs, enabling vendors to reuse their software.

TI developed the TCI6616 base-station SOC to incorporate field-proven PHY technology, an autonomous packet-processing engine, and programmable DSPs. The company implemented these elements as configurable coprocessors, which enable SDR (software-defined radio). SDR allows operators to rationally migrate to emerging standards without needing external components. Autonomous packet processing in the TCI6616 manages packets from both core and radio networks, offloading packet processing and freeing cycles for algorithms that enhance spectral efficiency.

Another company addressing smart-

grid and related green applications is Samsung Electro-Mechanics. Last fall, Chief Executive Officer Jong-Woo Park commented that, in the smart-grid sector, Samsung is now involved in power conversion, including photovoltaic inverters and smart meters for remote measuring, and module services. The company is also participating in various test-bed projects that the South Korean government has organized, and it plans to expand into drive motors, electric-power-control systems, quick chargers, and parts for automotive electrical systems by leveraging its power-supply and motor technologies. The future strategy is to expand into energy; environmental protection; electric-vehicle parts; and biotechnology, for which the company is adapting MEMS technology it obtained through its ink-jet-printer business, by taking advantage of convergence and modularization.

Other key product categories at Electronica included sensors and sensor interfaces, which exhibitor Austriamicrosystems highlighted in its often-crowded booth. Thomas

Reiner, director of marketing communications, describes the company as focused on power management, audio, and sensors and sensor interfaces, with sensing being the broadest application the company supports. The company also works on routing sensor data to its appropriate destination; on the Electronica floor, for example, Johnsy Varghese, marketing manager for wireless, demonstrated wireless transceivers for applications such as body-area networking.

In addition to acquiring, conditioning, and transmitting environmental information, a key focus for Austriamicrosystems is indicating user intent to the digital domain, according to Alfred Binder, marketing manager for the company's industry- and medical-business unit. Binder demonstrated the company's EasyPoint technology, which represents Austriamicrosystems' first foray beyond ICs to a complete module, which can replace joysticks and trackballs on mobile devices. An

EasyPoint device comprises a mechanical stack incorporating a navigation knob with a magnet and a 2-D encoder in the form of a contactless sensing IC. Cursor-travel rate in response to user inputs is proportional to how far off center the user nudges the navigation knob, making it easy to scroll forward and reverse through a video or navigate around a map. According to Binder, the performance aspects of the EasyPoint device will become increasingly attractive as mobile-device-processor speeds increase and users expect more control over the experiences the devices offer. EasyPoint works with sealed devices; the magnetic field from the magnet that attaches to the EasyPoint knob can penetrate an aluminum casing to the internal EasyPoint Hall-effect sensor and decoder IC.

An EasyPoint device is a 2-D Hall-effect device; travel of the navigation knob in the third dimension activates the binary "select" function of a mouse-button click. But the company also offers full 3-D Hall-effect capabilities with its HallinOne 3-D magnetic-encoder family, which it introduced at Electronica and which it developed in cooperation with Fraunhofer IIS (Institute for Integrated Circuits), the license holder of the HallinOne technology.

Austriamicrosystems' new AS540x implementation of the technology makes the absolute-position information of a simple two-pole magnet directly accessible over an SPI or a PWM interface. A HallinOne device uses two "pixel cells" in a differential mode to eliminate external influences from stray magnetic fields. Austriamicrosystems' AS540x IC contains an EEPROM to enable system designers to program and linearize the IC. The HallinOne device targets industrial and automotive applications. Andreas Pflingstl, marketing manager in the automotive-business unit, demonstrated the device with steering-wheel and clutch-pedal application as well as a gear-shift-by-wire application.

PURSuing ULTRASOUND

At Electronica, Analog Devices focused on data converters. The company announced products with embedded data-conversion technology, including eight-channel Doppler ultrasound receivers; a differential amplifier that attenuates high-voltage signals down



SEMICONDUCTOR EXECUTIVES ASSESS WHERE WE'RE GOING

By Brian Dipert, Senior Technical Editor

During a panel discussion at Electronica, semiconductor executives addressed the question, "What lessons have we learned from the crisis?" Participants included Peter Bauer, chief executive officer of Infineon; Henri Richard, senior vice president of global sales and marketing for Freescale (standing in for Freescale Chief Executive Officer Rich Beyer); Carlo Bozotti, chief executive officer of STMicroelectronics; and Rick Clemmer, chief executive officer of NXP. The discussion centered on how the current economic crisis differs from the one that occurred in 2001, to what extent relations with suppliers have changed, and what consequences and risks arise through the sometimes-long delivery times and allocations.

The executives echoed some variation of a common belief that the tech industry was probably entering a more normal period of growth—in the 5 to 10% yearly range—for at least the next several years. However, they also pointed out that their abilities to predict the future were limited, with their abilities to influence it being even less so. But Freescale's Richard pointed out that it was unrealistic for the semiconductor industry, which disruptive innovation founded and fueled, to simultaneously expect to be the beneficiary of ongoing stability coming from its investors and customers.

Looking at the past few years' worth of economic turmoil, Infineon's Bauer clarified his perceived view of it versus the earlier 2001-era "dot-bomb" upheaval. In the dot-bomb case, the root cause was "irrational exuberance" on the supply side, fueled by what ended up being unrealistically high demand projections from customers. Once the market belatedly realized that dot-com momentum had slowed and that the investment bubble was about to burst, it reacted with a brusqueness that led to abrupt order cancellations throughout the supply chain, leaving semiconductor suppliers and their foundry and manufacturing-equipment partners with abundant unsold inventory and capacity that took many years to be consumed.

This time, on the other hand, the fundamentals of customer demand were solid, but the United States and then the rest of the world faced a credit-availability crisis that paralyzed ongoing business viability throughout the economy. STMicroelectronics' Bozotti commented that events in late 2007 had great personal relevance for him, as he was negotiating with Intel to spin off his company's flash-memory group into the jointly owned Numonyx, which Micron Technology subsequently acquired. The lack of available credit greatly complicated and extended the duration of the spin-off and merger transaction. Early 2008 was characterized by severe, unprecedented currency fluctuation, he said. By late 2008, the world market had entered a major economic crisis. Throughout this time, only three countries—Brazil, India, and China—experienced positive economic growth. Several panelists hoped that the

countries' increasing effect on the world economy would in the future counterbalance potential irregularities in historically strong markets, such as the United States.

Irrational exuberance is not a phenomenon solely restricted to the early days of this decade. However, this time, the panelists said, semiconductor vendors' customers are exhibiting the phenomenon. The executives all believed that credit-crunch concerns—not any fundamental cessation in customer demand—drove the temporary lull in IC sales that began in late 2007. As such, once preliminary indicators of a market rebound occurred, IC demand returned with a vengeance to refill the supply chain.

The panelists all bemoaned their customers' unrealistic expectations of their abilities to respond with nearly instantaneous speed and nearly infinite shipment volumes. These items have coupled with the inevitable order cancellations of recent days as the supply chain again becomes satiated. Panelists also grumbled about their foundries' and manufacturing-equipment suppliers' failure to invest sufficiently over the past few years, which has increased leadtimes. Freescale's Richard spoke about the fact that Freescale took an equipment vendor to task for its poor product availability. The vendor responded by pointing out that each piece of equipment included approximately 100 Freescale microcontrollers and that Freescale's processor shortages were hampering the company's ability to build systems to turn around and sell back to Freescale.

Near-term "normalization" bumps aside, the long-term prognosis appears to be positive, with the executives showing enthusiasm for budding consumer demand in the Brazilian, Russian, Indian, and Chinese economies. But plenty of semiconductor "homes" continue to exist in more mature markets, too. Freescale's Richard, for example, pointed out that the US automobile market for many years ran at a 16 million- to 18 million-unit-per-year sales clip, much faster than population and household growth trends would suggest. Ultimately unsustainable financing schemes, such as home-equity loans, fueled this growth. Conversely, over the past several years, US car buyers have purchased only approximately 9 million cars. However, given that car vendors must sell approximately 12 million cars per year just to maintain the status quo—that is, replace those that wear out—more robust automobile demand will inevitably return.

Richard believes that economists are not sufficiently factoring into their forecasts the reality that the digital-savvy demographic population that grew up during the 1980s is now coming into full stride as consumers, with the potential result being tremendous sales opportunities. STMicroelectronics' Bozotti revealed that his company is tracking trends in affordable health care; safe, secure data protection; and energy conservation.

Read more on this topic at www.edn.com/110106cs.



to the input range of ADCs; an ultra-low-power radio SOC that integrates an ADC, a microcontroller, and an RF transceiver; MEMS iSensor 6°-of-freedom inertial-measurement units; and a three-axis MEMS iSensor vibration-analysis system with an integrated Blackfin processor. Although the word “green” did not appear in a presentation from company executives, the need for efficiency was obvious in many applications the executives cited, including portable health-care equipment, automotive electronics, and wireless communications.

Analog Devices introduced the ADu-CRF101 radio SOC, which includes an ISM-band RF transceiver; a six-channel, 12-bit SAR ADC that operates at 1M sample/sec; and a 32-bit ARM Cortex-M3 RISC microcontroller with SRAM and flash memory. The ultra-low-power radio SOC operates at 1.8 to 3.6V and features six sleep modes.

Analog Devices also highlighted the AD9278 and AD9279 fourth-generation octal ultrasound receivers, which reduce the power and board area for clockwise Doppler processing. The AD9279 is suitable for high-end and midrange systems, offering high image quality, fine resolution, and deep penetration, whereas the AD9278 targets use in portable ultrasound systems.

Other companies addressing low power for green- and portable-system applications at Electronica include Avago, Maxim, Renesas, and Rohm.

Avago announced a line of fiber-optic transmitters and receivers for harsh temperature environments. The HFBR-152xETZ/252xETZ fiber-optic modules provide reliable data transmissions over cost-effective plastic or silica fiber in the -40 to +85°C extended-industrial temperature range. Designers can use the devices to implement system control or drives in wind turbines and solar farms, traction inverters in trains, and other industrial applications and medical systems.

For similar renewable-energy applications, Avago announced the ACNV-4506 optocoupler, which meets the creepage and clearance distances for applications involving 1700V IGBTs (insulated-gate bipolar transistors). The optocoupler is available in a 500-mil, 10-pin DIP as well as a gull-wing-lead option for standard surface-mount processes, both with 13-mm creepage and clearance that meets the IEC (International Electrotechnical Council) 60664-1 standard. The package provides a minimum CMR (common-mode rejection) of 30 kV/μsec.

For automotive applications, Avago announced an optocoupler with extended-temperature operation for use in hybrid and electric vehicles. The highly integrated ACPL-38JT incorporates an IGBT driver for signal switching, along with desaturation detection and fault-status-feedback systems for constant signal protection. The device is part of the Avago R2Coupler family of optocou-

plers with reinforced insulation. Avago also announced high-power cyan LEDs for traffic signals. The new ASMT-JC11 and ASMT-AC00 1-W LEDs offer high lumen output and high energy efficiency in small-footprint packages. This combination of features targets traffic signals; sign backlighting; and architectural-, commercial-, and decorative-lighting applications.

Maxim highlighted medical, LED, energy-measurement, power-line-communications, and automotive applications. The company demonstrated an infusion pump that includes more than 20 Maxim parts, as well as a development kit for blood-glucose meters that uses the MAX1358 precision analog front end. Maxim also showcased its eight-channel MAX2079 front end for ultrasound applications.

For LED applications, Maxim highlighted its MR16 lamp drivers. A related demo employed the company's MAX2990/MAX2991 power-line data-communications chip set to control RGB (red/green/blue) LEDs at video rates. It also displayed the 71M6543 utility-metering and 78M6612 energy-measuring devices in a smart-grid demonstration. For automotive-infotainment applications, Maxim highlighted its GMSL (gigabit-multimedia-serial-link) technology.

Also at Electronica, EnOcean GmbH announced its ECT 310 ultra-low-voltage dc/dc converter, which enables batteryless wireless modules to use heat produced by operating machinery, radiators, or the human body as their power source. The ECT 310 works as an interface between thermoelectric converters and EnOcean modules. The converter converts input voltages of 20 mV to 3 and 4V levels. Vicor presented its PFM (pulse-frequency-modulation) VI Brick module, an isolated ac/dc converter with PFC. With its adaptive-cell architecture, it enables high efficiency over worldwide ac mains, delivering 330W at 48V SELV (safety extra-low voltage) in a package having a 9.5-mm profile.

Renesas introduced its RX600 microcontrollers, which reduce standby-mode power consumption by approximately 90%. It also reduced the size of its 16-bit IO-Link microcontrollers by 56% and introduced power MOSFETs in compact HSON-8 packages for automotive applications.



Figure 4 Rohm and Oki Semiconductor jointly developed a dedicated chip set for Intel Atom E600 series processors targeting low-power portable applications (courtesy Rohm).

TEAMING UP ON ATOM

Many of the product introductions touted at Electronica resulted from teamwork—the cooperative efforts of Austriamicrosystems and Fraunhofer IIS on the HallinOne technology, for example, and STMicro's use of Omron MEMS technology. In another example, Rohm announced a collaboration with its affiliate, Oki Semiconductor, on the development of a dedicated LSI circuit family to support the Intel Atom processor E600 series (Figure 4). The chip set comprises a power-management IC, a clock-generator IC, and an I/O-hub IC. The companies exploited Rohm's analog technology plus Oki's low-power-logic capabilities.

Rohm's power-management IC supplies all of the voltage rails for the Intel Atom EG20T processor platform-controller hub as well as for the DDR2 memory and BIOS-storage SPI flash that connect to the Atom chip. It also controls start-up and power-down sequencing that eliminates the need for an external microcontroller or a CPLD (complex programmable-logic device). Rohm's clock-generator IC provides all of the clocks the Atom requires; the controller hub; and the commonly



Figure 5 In cars with start/stop, the supply voltage for onboard electrical equipment can fall as low as 6V when a user turns off and restarts the engine. The TDA7850LV audio power amplifier enables in-car-entertainment equipment to operate without interruption during the power-supply dip (courtesy STMicroelectronics).

FOR MORE INFORMATION

Analog Devices Inc
www.analog.com

Austriamicrosystems
www.austria
microsystems.com

Avago Technologies
www.avagotech.com

Electronica
www.electronica.de

EnOcean GmbH
www.enocean.com

Fairchild
Semiconductor
www.fairchildsemi.
com

Fraunhofer Institute
for Integrated Circuits
www.iis.fraunhofer.de

Freescale
Semiconductor
www.freescale.com

Infineon
www.infineon.com

Intel Corp
www.intel.com

Linear Technology
Corp
www.linear.com

Maxim Integrated
Products
www.maxim-ic.com

Micrel Inc
www.micrel.com

Micron Technology
www.micron.com

NXP Semiconductors
www.nxp.com

Oki Semiconductor
www.okisemi.com/en

Omron Corp
www.omron.com

Renesas Electronics
www.renesas.com

Rohm Co Ltd
www.rohm.com

Samsung
Electro-Mechanics
sem.samsung.co.
kr/en

STMicroelectronics
www.st.com

Strategy Analytics
www.strategy
analytics.com

Texas Instruments Inc
www.ti.com

Tyco Electronics
www.tycoelectronics.
com

Vicor Corp
www.vicorpower.com

employed external SATA (serial-advanced-technology-attachment), USB, and similar interfaces.

Oki Semiconductor's contribution includes two application-specific I/O hubs, the ML7223(V) and the ML7213. The ML7223(V) serves telecom-terminal applications, such as Web-enabled media phones. It integrates industry-standard I/Os, such as USB, SATA, SD (secure digital)-Host, and UART (universal asynchronous receiver/transmitter), as well as application-specific functions, including an IPsec (Internet Protocol-security) hardware accelerator and echo and noise cancellers for hands-free operation. The ML7213 primarily serves in-vehicle information and entertainment applications. It includes a built-in MediaLB (media local bus), an SDVO (serial-digital-video-output) converter, and a video-input interface as well as industry-standard I/O.

GREEN CONSEQUENCES

Sometimes, green initiatives can lead to unintended consequences. For example, car makers are offering a start/stop feature, which, with other engine-management programs, could ultimately cut fuel consumption by as much as 20%. STMicroelectronics cites a Strategy Analytics study saying that annual demand for vehicles featuring start/stop should reach almost 20 million units by 2015. Customer demand in Europe initially led this drive.

Unfortunately, in a car with start/stop, the supply voltage for onboard electrical equipment can fall to as low as 6V when the engine restarts, causing

temporary silence or noticeable distortion in the output of the vehicle's audio system. STMicroelectronics identified this problem as an opportunity and is introducing chips that power the in-car-entertainment systems throughout the stop/start sequence. The first such device is the TDA7850LV, a 4x50W audio power amplifier that makes it unnecessary to add discrete components to regulate the supply voltage and suppress pop and click noises (Figure 5).

You can expect many more green innovations throughout the coming year. For example, Rick Clemmer, executive director, president, and chief executive officer of NXP, says that the company is focusing on CFL (compact-fluorescent-lamp)-IC drivers and will begin to ramp up production in the first quarter of this year (Reference 1). As 2011 progresses, expect vendors to develop new power-saving devices or those like STMicro's TDA7850LV that mitigate the unwanted side effects of green technology. **EDN**

REFERENCE

1 Deffree, Suzanne, "NXP CEO: Capacity a challenge, but opportunity abounds," *EDN*, Nov 2, 2010, <http://bit.ly/cGcP6Q>.



You can reach
Editor-in-Chief
Rick Nelson
at 1-781-869-7970
and [richard.nelson@
ubm.com](mailto:richard.nelson@ubm.com).

Using enhanced triggering to verify and debug complex designs

THE USE OF SOPHISTICATED TRIGGERS PLAYS A KEY ROLE IN IDENTIFYING PROBLEMS FROM DESIGN VERIFICATION THROUGH TO DEBUGGING AND TROUBLESHOOTING.

Analyzing systems that always fail is not difficult. The more difficult challenge is to debug systems such as a clock that intermittently outputs an incorrect duty cycle or a rise time that occasionally fails specifications. Adding to the challenge are complex high-speed serial buses that use CDR (clock-data-recovery) techniques for data transmission or specialized 8b/10b encoding schemes. A further level of complexity is the trend toward multilane serial configurations.

As waveforms become more complex, the basic edge trigger has become too limited as the sole means of initiating an acquisition. Edge triggering simply doesn't give the oscilloscope enough useful information about when to start capturing a waveform, making it difficult to find infrequent errors. Fortunately, trigger capabilities have evolved to keep pace with the increase in signal complexity.

Advanced triggers, available in the latest generation of oscilloscopes that handle next-generation high-speed requirements, respond to more rigorously specified conditions in the incoming signal, allowing the detection, for example, of a pulse that is narrower than it should be. Other trigger events include amplitude-defined pulses, such as runts or pulses; time-qualified events, such as pulse width, glitch, slew rate,

setup-and-hold time, and time-out; both amplitude and time using window triggering; or logic-state- or pattern-delineated events, such as logic triggering. Such conditions would be impossible to detect with an edge trigger alone.

SEQUENTIAL AB TRIGGERING

In the most demanding applications, a single trigger event is not sufficient to fully define the circuit behavior that creates the event of interest. It is often desirable to trigger on a sequence of events. The first, or A, event arms, or prequalifies, the triggering event, and the second, or B, event triggers on the point of interest.

In many oscilloscopes, the A, or main, trigger is a fully featured system that incorporates advanced triggers, and the secondary, or B, trigger performs edge-style detection. The A trigger acts as a qualifier. Its occurrence enables the B trigger to look for a defined voltage threshold. Additionally, some oscilloscopes use dual A- and B-event triggering—complementary trigger circuits with advanced trigger qualification on both the A and the B events.

Another useful tool is trigger reset as part of the AB-sequence system. This approach directs the instrument to stop waiting for a B event when the system meets a reset criterion. The combination of reset triggering and dual A- and B-event triggering increases the range of standard trigger-



Figure 1 This 5-Gbps PCIe bit stream has 8b/10b encoding triggered on a run-length sequence.

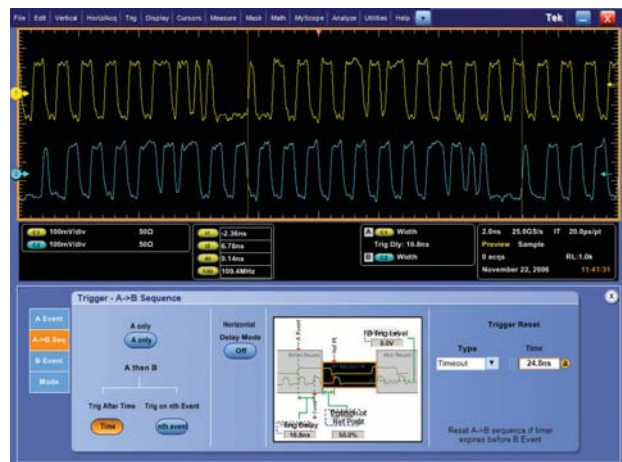

Figure 2 The oscilloscope triggers on a lane-skew violation.

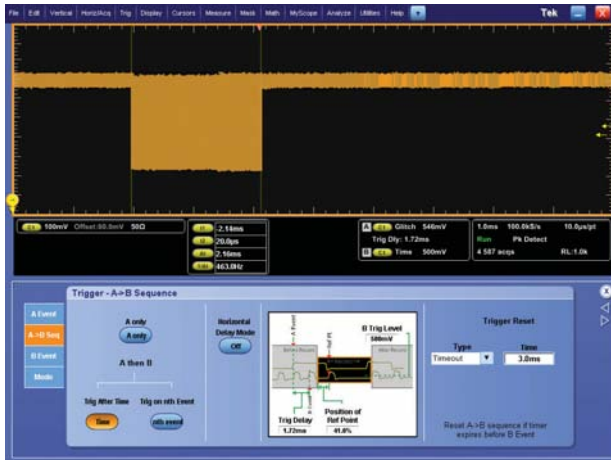

Figure 3 This beacon signal fails a minimum 3-msec specification.

ing selections from a maximum of approximately 17 to more than 1400, leading to faster and more precise error trigger and capture.

VALIDATE HIGH-SPEED SERIAL-BUS DESIGNS

Serial buses have become the norm for high-speed signal transmission. Standards such as SuperSpeed USB (Universal Serial Bus) 3.0, PCIe (Peripheral Component Interconnect Express), XAUI (10-Gbit attachment-unit interface), InfiniBand, and SATA (serial advanced-technology attachment) transmit data and clock signals using differential signals. The data embeds the clock, and the system often uses 8b/10b encoding to provide a means of reliable clock extraction. Multilane implementations of these technologies bring further complexities. Four, eight, or more serial lanes carry signal components from transmitters to receivers, all with the goal of higher data throughput. You can use advanced triggering for validating and characterizing these multilane serial buses.

Serial pattern triggering provides the ability to capture unique bit sequences on serial buses. The data in pattern triggering can be either serial, with an embedded clock, or parallel, with a separate clock. Serial pattern triggering can trigger on a specified pattern as long as 64 bits, or 40 bits for 8b/10b encoded serial data, providing a debugging tool for a variety of serial buses. **Figure 1** shows a 5-Gbps PCIe bit stream with 8b/10b encoding triggered on a run-length sequence.

Multilane high-speed serial-communication links work effectively only when the lanes are time-aligned within specific tolerances. Engineers sometimes use oscilloscopes to measure the time skew between lanes by triggering on single characters in one data stream and observing the amount of skew time among the lanes. However, these basic measurements do not confirm that the lanes remain time-correlated in the longer term.

The use of a trigger for serial-lane-skew violation solves this problem by triggering on out-of-tolerance time skew between any two lanes. You can perform pass/fail tests for lane-skew violation using dual A and B triggering. The oscilloscope triggers on out-of-tolerance time skews between the lanes over any period: minutes, hours, and even days or longer. The display can capture any event that violates the

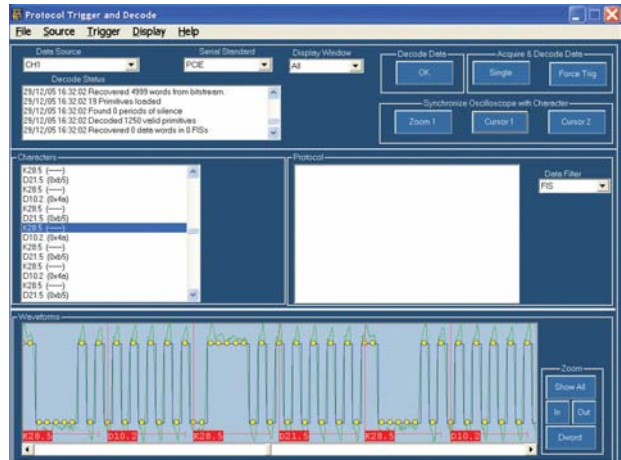

Figure 4 PTD software automatically decodes 8b/10b data from the acquired waveform, a high-speed serial signal.

skew time and counts these violations using the acquisition counter.

The width trigger captures the first trigger event, or A event, from Lane 0, which is a comma, and the second trigger event, or B event, on Lane 1, which also represents a comma. The specification requires that the same event on Lane 1 must occur no more than 24.8 nsec after the event on Lane 0. You use delay to set up a minimum time to start looking for the B event, and the reset trigger is set to 24.8 nsec, the specification tolerance. **Figure 2** shows the oscilloscope triggering on a lane-skew violation.

BEACON-WIDTH-VIOLATION TRIGGERING

Serial-communication devices complying with standards often announce their presence on a communication channel at power-up by emitting a beacon signal comprising packet headers and variable-length data blocks. When the device powers up into an error condition, the beacon signal contains additional information and persists for a longer time. It previously was impossible to trigger when these variable-length beacon signals violated the limited width.

Full A- and B-event definitions are helpful in solving this problem. The A event detects the K28.5 comma in the beacon signal's header packet by triggering on the width of the five ones or five zeros in the character. The trigger hold-off is greater than the beacon-signal width, so the A trigger event occurs only at the beginning of the beacon signal.

The B event notes the end of the beacon signal by using a time-out trigger to detect the idle state of the signal. The end of the trigger-delay time, which is the beacon-width specification, defines the beginning of the beacon-width-violation time window. The reset time-out defines the end of the beacon-width-violation time window. With this trigger setup, the oscilloscope triggers only when the end of the beacon signal occurs within the violation time window. **Figure 3** shows a beacon signal that fails a minimum 3-msec specification.

As the name implies, a time-out trigger allows a user to trigger on an event that remains high, low, or either for a specified time. Developers sometimes design dead times in clock or data signaling into a system. However, if designers do not properly time these dead times with other system



Figure 5 This SERDES-based trigger can respond to disparity and character errors in real time.

events, they can cause system-communications errors. It is often useful to trigger on these dead times to discover whether they exist and then to investigate their timing with other signals.

8b/10b PROTOCOL TRIGGER AND DECODE

PTD (protocol-trigger and -decode) software is available to automatically decode 8b/10b data from the acquired waveform, a high-speed serial signal (**Figure 4**). A listing of the symbols on the screen supports validation of the digital data. **Figure 5** shows a trigger-setup menu for the PTD software. Using these controls, you can set up the oscilloscope to trigger on any four symbols, or 40 bits, of the 8b/10b data. This SERDES (serializer/deserializer)-based trigger can also respond to disparity and character errors in real time.

TRIGGER-QUALIFIED JITTER ANALYSIS

Most serial transmission standards call for a BER (bit-error ratio) of one part per trillion or better. You can make serial validation measurements on timing, amplitude, and jitter behavior using serial data-compliance and -analysis software. Such software typically uses a spectrum approach to provide an estimate of total jitter at a BER of 10 to 12.

You can perform analysis on either an arbitrary pattern or a repeating pattern. Industry groups develop test patterns for signal-integrity measurements to standardize measurement methods and to stress the device under test with worst-case scenarios. It is often desirable to make a jitter measurement on a section of the waveform. Trigger qualification is the key to implementing this procedure.

Consider the example of a lone-bit pattern from a SATA II device. The lone-bit pattern is a defined set of words that contains lone bit 00001000, which differs from all those bits that surround it. Assuming a bit interval of 333 psec, the 00001000 lone-bit expression equates to a negative pulse of 1.33



Figure 6 You use the AB-sequence trigger, with the A event set to trigger on the 0000 sequence before the lone bit and the B event set to trigger on the 0000 sequence after the lone bit. With a stable trigger on the lone-bit pattern, you can now perform the jitter and eye analysis on as many consecutive triggers as necessary.

nsec. A 333-psec positive pulse and a 999-nsec negative pulse follow the 1.33-nsec negative pulse. To perform trigger-qualified jitter analysis, you must distinguish the lone-bit pattern as a unique entity within the data stream.

One option might possibly be to use the 8b/10b trigger running at 3 Gbps to detect the lone-bit pattern and trigger the instrument. However, the 8b/10b trigger relies on comma characters to synchronize the trigger system. In this case, you must rely on the bit-by-bit precision of the trigger system to locate the lone-bit pattern. You use the AB-sequence trigger, with the A event set to trigger on the 0000 sequence before the lone bit and the B event set to trigger on the 0000 sequence after the lone bit. With a stable trigger on the lone-bit pattern, you can now perform the jitter and eye analysis on as many consecutive triggers as necessary. **Figure 6** shows the trigger setup of the lone-bit pattern.

BUS-QUALIFIED TRIGGERING

When hardware and software engineers are working together to troubleshoot the root cause of a problem, they require a view of electrical-bus information and a higher level of abstraction, such as the decoded view of a serial- or a parallel-bus protocol. You can use a high-performance MSO (mixed-signal oscilloscope) to qualify signal capture using the state of command and control lines on a memory bus.

SDRAM commands synchronize to the rising edge of the CK (memory clock). The four command signals are S0# or CS# (chip select), RAS# (row-address select), CAS# (column-address select), and WE# (write enable). The # symbol indicates that these signals are active-low (**Table 1**). The verification of memory commands requires the MSO to probe signals CK, S0#, RAS#, CAS#, and

TABLE 1 SDRAM COMMANDS

Command	S0#	RAS#	CAS#	WE#
Mode register	0	0	0	0
Refresh	0	0	0	1
Precharge	0	0	1	0
Activate row	0	0	1	1
Write column	0	1	0	0
Read column	0	1	0	1
No operation	0	1	1	1
Deselect	1	X	X	X

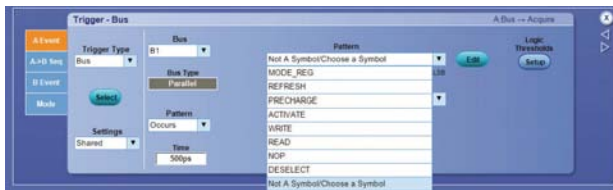

Figure 7 MSOs work with data in binary, hex, and symbolic formats.



Figure 8 You use pattern-symbol files when a group of signals define a logical state, such as the SDRAM-command group.

WE#, in addition to acquiring the appropriate DQ (data) and DQS (strobe) signals. You assign these commands to probe channels on an MSO.

The activate-row command is the first command of a write or read command sequence. To trigger the MSO on the activate-row command, configure the MSO to trigger on a command group equal to 0011. This group includes S0#=0, RAS#=0, CAS#=1, and WE#=1. Dealing with binary values such as 0011 can be error-prone. To overcome this problem, MSOs work with data in binary, hex, and symbolic formats. You use pattern-symbol files when a group of signals define a logical state, such as the SDRAM-command group. **Figure 7**

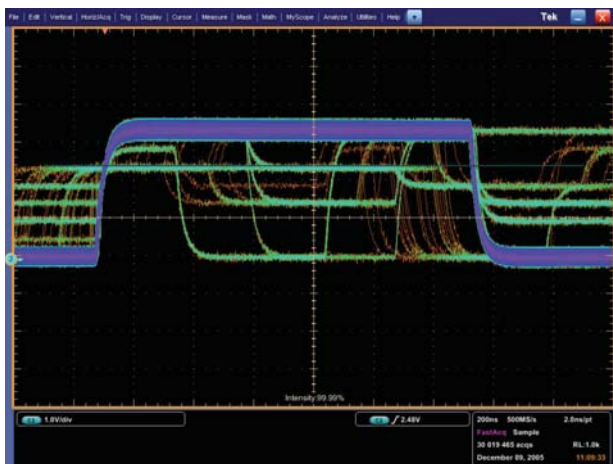

Figure 9 The lighter trace areas indicate areas that the waveform has touched less frequently.

shows a symbol-trigger menu with DDR commands, and **Figure 8** shows DDR3-command-bus decoding.

BEYOND TRIGGERING

As the previous examples show, triggering is a good approach if you understand the nature of the error. But what happens if you don't know the cause of the signal degradation? In this case, an oscilloscope with a high waveform-capture rate can increase the probability of seeing problems such as runt pulses, glitches, and timing issues. Such processing architectures allow continuous waveform-capture rates as high as 300,000 waveforms/sec. By comparison, the typical DSO (digital-storage-oscilloscope)-waveform-capture rate is approximately 8000 waveforms/sec.

DPOs (digital phosphor oscilloscopes) convert this digitized waveform data into a waveform image from a waveform database. Approximately once every 1/30th of a second—as fast as the eye can perceive it—a snapshot of the signal image stored in the DPO transmits directly to the display system. The high capture rate of a DPO means that it is more likely to acquire infrequent events. An intensity-graded color display allows the user to distinguish even a one-time event amid thousands of cycles of the waveform.

You can use the capture of additional information to gain more insight into the nature of errors. As **Figure 9** shows, the lighter trace areas indicate a lower frequency of occurrence, or areas that the waveform has touched less frequently. The aberration in this case is a secondary waveform exhibiting phase shift and occasional truncated pulse amplitudes. Now that you can see the anomaly—whether it is an incorrect pulse width, intermittent lower voltage, or an occasional slower rise time—you can now go back and set up the enhanced triggering to isolate and debug the event of interest.

Today's oscilloscope applications range from capturing random events of just a few picoseconds' duration to long-term monitoring and analysis. Edge triggering is no longer sufficient for verification and debugging. Learning to use enhanced triggering systems can significantly speed validation and debugging of complex signals in modern computing, serial-data-transmission, and communications systems. High-speed MSOs allow triggering on parallel-bus commands, helping hardware and software engineers work together efficiently to isolate problems. When you don't understand the nature of the error, an oscilloscope with a high waveform-capture rate and digital phosphor display can help reveal infrequent errors, which you can then trigger using enhanced trigger capabilities. **EDN**

AUTHOR'S BIOGRAPHY

Jit Lim is the senior technologist for high-speed signal analysis at Tektronix, where he has worked for 23 years. He has extensive experience in signal integrity, jitter analysis, and physical-layer characterization of high-speed signals. Lim has published numerous technical papers and has helped many leading-edge technology companies with their test-and-measurement challenges. He has also designed some of Tektronix's highest-performance real-time scopes and jitter-analysis products. Lim holds a bachelor's degree in electrical engineering from the Massachusetts Institute of Technology (Cambridge, MA).

Designing battery-management systems

AVAILABLE BATTERY-FUEL-GAUGE PRODUCTS BRING CHALLENGES AND LIMITATIONS, ESPECIALLY WHEN YOU APPLY THEM TO THE BATTERY-MANAGEMENT FUNCTION. HERE ARE SOME GUIDELINES FOR ENGINEERS WHO ARE DESIGNING BOTH PORTABLE DEVICES AND THE BATTERIES TO POWER THEM.

Battery-fuel-gauge ICs, or gas gauges, are at the heart of modern battery-management systems. They not only maintain accurate estimates of the capacity remaining in the battery but also can serve as the host's battery-data-acquisition and -management system, primary battery-protection device, and cell-balancing system, as well as maintain records of battery-use history. Some gas-gauge systems comprise an analog-front-end IC that provides the high-speed protection and voltage-measurement capabilities and the gas-gauge IC that maintains the capacity estimate and other more complex functions. Increasingly, one IC combines the analog-front-end and gas-gauge functions.

A range of fuel-gauge ICs is available and targets use in a number of applications. These ICs include single-cell batteries, multicell batteries with as many as 13 cells in series, system-side fuel gauges, and gauges with and without built-in primary protection. Gauge ICs are available from a number of large semiconductor vendors, including Atmel, Intersil, Maxim Integrated Products, O₂Micro, and Texas Instruments (references 1 through 5).

Single-cell gauges usually have small PCB (printed-circuit-board) footprints for tight circuit-layout situations. These tiny cell gauges target use with batteries with only one cell in series, or 1S (one-serial) batteries in battery terminology. The battery may have as many parallel cells as necessary, such as the 1S1P (one serial/one parallel), 1S2P (one

serial/two parallel), 1S3P (one serial/three parallel), and so forth. Examples of these gauges include the TI bq275xx, the O₂Micro OZ8805, and the Maxim DS278x series. Although some single-cell gauges have built-in protection logic, most require the use of a separate protection IC (for example, the Seiko Instruments S-8211 or S-8241, Reference 6). The low core voltages in ultra-portable devices and the high voltage and energy density of lithium-ion cells combine to produce an effective portable power system. Linear Technology's LTC2941 and LTC2942 single-cell gas gauges implement a coulomb counter, which integrates the current into and out of the cell array, with a fast analog integrator (Reference 7). This technique may allow accurate tracking of pulsed load current, which is a chal-

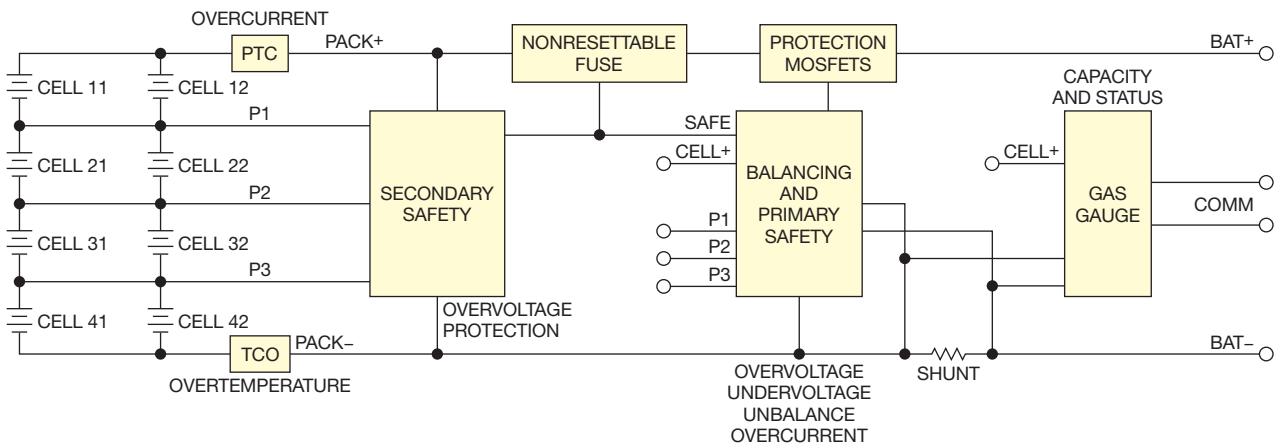

Figure 1 This battery has four cells in parallel connection and four cells in serial connection (4S4P).

lenge for sample-data-system coulomb counters.

A wide selection exists for gauge ICs for multicell batteries of 2 to 4S (two to four serial). They include the TI 20zxx series and the O₂Micro OZ9310. The 3 or 4S (three or four serial) battery configuration is popular for portable devices because you can derive most core voltages for complex portable electronics devices from the minimum voltage available from a 3 or 4S lithium-ion battery using simple point-of-load buck or linear regulators—approximately 9V for a 3S battery and approximately 12V for a 4S battery.

Once the series cell configuration in the battery exceeds 4S, fuel-gauge-IC choices become limited. The relatively new TI bq78PL114 and several O₂Micro offerings can handle high-S-count batteries. Some gauges support high-S-count batteries using external extension ICs. High-S-count batteries find use in electric vehicles and other high-energy motor-drive applications. In these applications, high battery voltage is necessary to avoid excessive current in the motor-control circuits, and batteries of several hundred volts are common. Many of these applications use full-custom microcomputer-based battery-management-system circuits to handle the highly complex management and protection tasks. **Figure 1** shows a typical 4S4P (four-serial/four-parallel) battery.

SAFETY FIRST

Battery safety must be a primary design consideration. Always design multiple layers of overvoltage, undervoltage, overcurrent, and overtemperature protection into all lithium-ion batteries, no matter how small. This protection should include PTC (positive-temperature-coefficient) devices for overcurrent conditions and TCO (thermal-cutoff) devices for overtemperature conditions in series with the cells. You should also use active secondary- and primary-protection circuits. Fuel-gauge ICs can provide primary protection, but that protection alone is not enough. Secondary active protection that opens an electronically controlled fuse, such as a Sony Chemical self-control protector, is often necessary (**Reference 8**).

Carefully analyze all circuit elements on the cell-array side of the protection

circuits. It's essential that no single-component fault causes a short circuit across one or more of the cells. For example, if a capacitor is necessary across a cell for bypassing EM (electromagnetic) noise, you should use two capacitors in series to minimize the chance that component failure will short-circuit the cell. Modern lithium-ion cells can deliver large currents for long times and cause "energetic events" on a PCB if a component fault short-circuits the cell. Do not depend on the cell's embedded overcurrent protection for this protection. Some cells lack such elements; on others, the current trip point is so high that it can damage the PCB before the cell opens. This consideration is especially important on high-parallel-cell-count batteries in which the maximum current from each cell can add to a large maximum battery current.

Do not strike an electrical arc when assembling the cell array to the battery-protection electronics. Such an arc can generate high-voltage transients that can damage the gas-gauge and protection-circuit elements. This damage may allow the device to work properly during factory test and then fail in field use. Protection circuits may not always be failsafe and thus can cause the protection circuit to fail when an actual fault occurs. For this reason, you should design multiple layers of protection into the battery.

HOSTS AND BATTERIES

Most fuel gauges support either a two-wire SMBus (system-management bus), such as an I²C (inter-integrated circuit), or a one-wire HDQ (high-speed-DQ) interface for communication with the host device, which can be a portable device or a charger. Several Maxim gauge ICs support the proprietary Maxim 1-Wire interface. You can use this interface to program the gauge IC during manufacturing and communicate many parameters with the portable host device and charger. Most gauges that support SMBus communication also support the SBS (Smart Battery System) 1.1 list of standard battery parameters (**Reference 9**).

The low signal reference for these digital-communication interfaces carries the return current for the battery. Be careful that the voltage drop between the gas-gauge reference to signal

Searching for Power?

Harsh environment

PFE Series



- ◆ 300 to 1500W
- ◆ 12 - 48V output
- ◆ -40 to +100°C ambient

Medical

SWS, NV, Vega & EFE series



- ◆ 15 to 1000W
- ◆ Single or multiple output
- ◆ 4kVAC isolation

Industrial

HWS



- ◆ 15 to 1800W
- ◆ 3.3 - 60V output
- ◆ Limited Lifetime Warranty

For more information on how TDK-Lambda can help you power your unique applications, visit our web site at

www.us.tdk-lambda.com/lp/

or call 1-800-LAMBDA-4

TDK-Lambda
Innovating Reliable Power

ground and the host-system ground is not excessive at high battery current. Digital signals may be unable to achieve a valid low at either the gas gauge or the host system during high-battery-current situations. This inability can be due to battery-to-host system-contact resistance, wire resistance, shunt resistors, or even PCB-trace resistance. Watch out for pulse-current situations, such as inrush current during battery connection, start-up current for host devices, or high charger current. These conditions may cause communication dropouts due to signal-ground lift.

CELL BALANCING

Manufacturers recommend cell balancing, either in the fuel gauge or in the protection IC, for 3 and 4S lithium-ion batteries and require it for 5S and larger batteries, and many gauge ICs have this feature built in. Cell balancing is necessary because the capacity of the individual cells can diverge as the battery cycles through charge and discharge. This situation is especially true if the battery often deeply discharges.

The simplest cell-balancing method, passive balancing, shunts current around each fully charged cell in the series stack until all cells in the stack have the same capacity. Fuel gauges that keep track of the relative capacity of each cell in the stack perform this task on each charge cycle. The Linear Technology LTC6802-1 is a cell-monitoring IC that implements this technique.

TI's bq78PL114 and some O₂Micro products implement a more complex cell-balancing technique, active balancing. This method controls small switching power supplies at each cell. These circuits pump current into the cell to balance it with the others in the stack. Control and circuit design for this method is fairly complex, but it optimizes charger energy and minimizes charge time.

CONNECTING THE GAUGE

The cell array, or core pack, of a high-S- and P-count battery can be complex. To ensure that the fuel gauge maintains an accurate available-capacity measurement, you must carefully wire the gauge voltage and current sense to the core pack. Also, many gas gauges require a first-connection order—usually from

the lowest to the highest voltage—during manufacturing to prevent damage to the IC.

When designing the battery, ensure that little current flows in the voltage-sense connections between the gauge IC and the core pack. This requirement usually calls for a separate sense wire, or Kelvin connection, between the cell's positive connection and the gauge IC. Also, be sure to follow the layout guidelines for the gauge IC you use, especially between the current shunt and the gauge IC.

CAPACITY ESTIMATES

To remain accurate, coulomb counting requires a known capacity starting point and precise current measurements. Most gas gauges reset their capacity estimate to the actual capacity of the cell array, or chemical capacity, when the battery is fully charged. However, the chemical capacity changes as the battery ages, so the battery must support some capacity-updating method. You can update a battery's chemical capacity by continuously discharging it from full charge to a low "training" voltage. This method, called conditioning the battery, is inconvenient for most battery users because it can take several hours and is usually a manual process. You can use conditioning chargers, but the controls and discharge circuits add significant cost to the charger.

A few years ago, TI developed the Impedance Track algorithm, which uses a model of cell-impedance change to update the cell's chemical capacity during normal battery use. The company has improved this algorithm several times, and it works for many battery-use models. Correct operation of the Impedance Track algorithm requires that during the battery's charge or discharge, two "relaxation" points occur at which the battery current is low and the battery voltage is in the flat portion of the discharge curve—that is, neither at full charge nor close to full discharge. You must space these two relaxation points more than approximately 40% apart in battery capacity. For example, if you fully charge your laptop computer's battery, use the computer on battery for a while, close the lid for a while, use it for a while longer, and then close the lid again. The Impedance Track algorithm will then likely have the information it

needs for a chemical-capacity update.

Some battery-use patterns do not allow the Impedance Track algorithm to operate properly. One of these patterns is the backup-battery-use model in which the battery almost always remains at 100% charge, rarely undergoes shallow discharges, and recharges immediately after a discharge. TI offers some white papers on its Web site about adapting the algorithm to this use model, but it's a complex process.

Maxim has developed the Model Gauge algorithm, which uses a carefully designed model of the voltage-versus-temperature-versus-capacity characteristics of cell types to update the cell's chemical capacity during normal battery use. Maxim is working with a small group of battery integrators on the first applications of this technique.

O₂Micro uses high-resolution cell-voltage measurements and a model of the voltage versus capacity to estimate cell capacity. The flat voltage-versus-capacity characteristics of high-capacity lithium-ion cells limit this technique, especially in extremely flat LiFe (lithium-iron) PO₄ cells, in which a 1-mV voltage change can equal a 1% change in the state of charge. Fuel-gauge-IC companies are working on improved voltage-measurement capabilities because of this limitation.

RUNTIME ESTIMATION

Estimating remaining portable-device runtime is among the most complex and error-prone aspects of battery use. The gauge must know how much power to source from the battery and the true chemical capacity of the cell array to report remaining runtime. The amount of power the portable device pulls from the battery may be inconsistent or unpredictable.

For portable devices requiring maintenance of accurate estimates of remaining capacity, you should set up a reserve capacity. When you program a reserve-capacity value into a gas gauge, it offsets the reported capacity by that amount. So, the gauge would always report a lower remaining capacity than is actually available from the cell array. This technique allows portable devices to safely complete whatever transactions they are doing before powering down due to a low-battery indication from the gas gauge. This approach is



Your Project Acceleration Resource for Electronics Manufacturing



Electronics[®] WEST

February 8-10, 2011

Anaheim Convention Center
Anaheim, CA

ElectronicsWestShow.com

Electronics[®] NEW ENGLAND

April 6-7, 2011

Boston Convention
& Exhibition Center
Boston, MA

Electronics-NE.com

Electronics[®] IPC Midwest

September 20-22, 2011

Donald E. Stephens
Convention Center
Rosemont (Chicago), IL

ElectronicsMidwest.com

Find the suppliers, tools, and services you need to make your product, process, and business more efficient, cost-effective, and profitable.

For information on attending or exhibiting, please call 310/445-4200 or visit CanonTradeShows.com

PICO

Surface Mount (and Plug In) Transformers and Inductors

See Pico's full Catalog immediately
www.picoelectronics.com

Low Profile from
.19" ht.



Audio Transformers

Impedance Levels 10 ohms to 250k ohms,
Power Levels to 3 Watts, Frequency Response
 ± 3 db 20Hz to 250Hz. All units manufactured
and tested to MIL-PRF-27. QPL Units available.

Power & EMI Inductors

Ideal for noise, spike and Power Filtering
Applications in Power Supplies, DC-DC
Converters and Switching Regulators

Pulse Transformers

10 Nanoseconds to 100 Microseconds. ET
Rating to 150 Volt Microsecond, Manufactured
and tested to MIL-PRF-21038.

Multiplex Data Bus Pulse Transformers

Plug-In units meet the requirements
of QPL-MIL-PRF 21038/27.
Surface units are electrical equivalents
of QPL-MIL-PRF 21038/27.

DC-DC Converter Transformers

Input voltages of 5V, 12V, 24V And 48V.
Standard Output Voltages to 300V (Special
voltages can be supplied). Can be used as self
saturating or linear switching applications. All
units manufactured and tested to MIL-PRF-27.

400Hz/800Hz Power Transformers

0.4 Watts to 150 Watts. Secondary Voltages 5V
to 300V. Units manufactured to MIL-PRF-27
Grade 5, Class S (Class V, 155°C available).

Delivery-Stock to one week
for sample quantities



for **FREE** PICO Catalog
Call toll free **800-431-1064**
in NY call **914-738-1400**
Fax **914-738-8225**

PICO Electronics, Inc.

143 Sparks Ave, Pelham, N.Y. 10803
E Mail: info@picoelectronics.com
www.picoelectronics.com

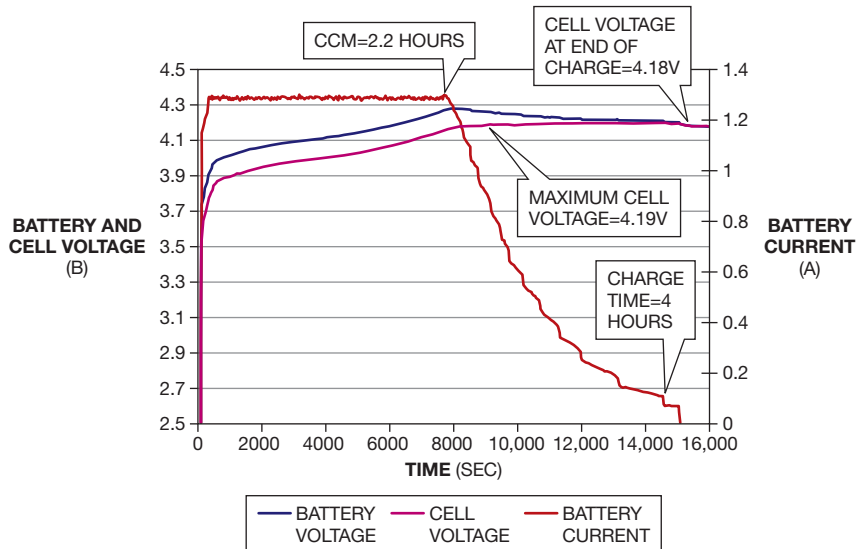

Figure 2 In a typical voltage-and-current profile for charging a single-cell lithium-ion battery, the battery voltage was measured inside the charger, and the cell-voltage value comes from the gas gauge.

similar to having a reserve gas tank on an airplane, providing just enough capacity to land when the main tank is empty.

SYSTEM, BATTERY GAUGES

System-side gauges reside in the portable host and must adapt to each battery as you connect it. Battery-side gauges reside in the battery and carry the battery characteristics as the battery moves. System-side gauges are more useful in applications in which the battery usually stays with the host—for example, laptop computers, PDAs (personal digital assistants), and cell phones. If you replace the battery in a device with a system-side gas gauge, that gas gauge will report erroneous information until you recalibrate it. Battery-side gauges work better in applications in which the battery is removed from the portable device for charging or moved between portable host devices.

System-side gauges must support a capacity-estimate-update algorithm that runs during normal battery use. Otherwise, the gauge would not know the chemical capacity of the battery unless you run a conditioning cycle. Portable hosts integrate system-side gauges, minimizing battery-electronics costs and eliminating the need for battery contacts for the communication interface.

Battery-side gas gauges integrate analog thermistor inputs to get accurate temperature readings from close prox-

imity to the cells. Another issue with system-side gas gauges is that the distance between the thermistor and the thermistor's input is greater. Hence, the thermistor's reading at the system-side gas gauge can be inaccurate.

Because battery-side gauges travel with the cell array, they can refine their chemical capacity estimate over time. They can also preserve capacity measurements that they completed during a conditioning cycle. However, the battery must have one or two additional contacts to support the battery-to-host communication interface.

CHARGERS AND GAS GAUGES

Battery chargers can be as simple as an ac-powered device, such as a cell-phone charger, or as complex as a multi-bay device with a display and communication with the batteries, such as those users might employ to charge a bank of portable military radios. Chargers generally come in two flavors: Smart chargers interact with the gas gauge in the battery during charge, and dumb chargers use only battery-terminal voltage and internally measured current to control the charge cycle.

Lithium-ion battery chargers maintain a specific current and voltage profile on the battery as a charge progresses. During the initial portion of the charge cycle, when the battery voltage is below the float voltage—that is, below the maximum for the type of cell

and series arrangement—the charger sources a CCM (constant-current mode) and allows the battery voltage to gradually increase. Once the charger reaches the float voltage, the charger maintains CVM (constant-voltage mode) and allows the current to taper off until it reaches a preset minimum value, at which point the charge terminates. Unlike with lead or nickel-cadmium batteries, you cannot trickle-charge lithium-ion batteries—that is, once the battery achieves full charge, you must turn off the charge current. Trickle-charging can damage lithium-ion batteries.

Chargers that interact with the battery's gas gauge have some advantages. The gas gauge measures the true voltage across the cell array and can report that voltage to the charger. The charger can measure the voltage only at the battery connector, and that voltage is usually higher than the cell array's voltage due to contact, wire, and current-shunt resistances. If the charger can control the gas gauge's measured cell-array voltage, it can maintain CCM longer, reducing charge time. Also, chargers that communicate with the gas gauge can use the precise current-measurement capability of the gas gauge, allowing the use of less expensive circuits in the charger.

Figure 2 shows a typical voltage and current profile for charging a single-cell lithium-ion battery. In this case, the battery voltage was measured inside the charger, and the cell-voltage value comes from the gas gauge. Note the advantage of maintaining CCM until the cell voltage reaches the 4.2V float voltage.

EM NOISE

Because battery-management systems contain high-impedance measurement circuits, they're susceptible to EM-noise pickup. Battery-powered portable systems, such as radio transmitters and motors in electronic vehicles, can themselves generate EM noise, or they can operate near an EM-noise source. The metal cans around the cells and the cells' interconnect strapping make efficient antennas for high-frequency noise.

Noise pickup in the cell array can cause reading noise in the gas-gauge voltage- and current-measurement system comprising the ADC and signal-

conditioning components. Gas-gauge ICs use analog and digital noise filters to reduce the problems this EM noise causes, but it can still be an issue in noisy environments. EM-noise spikes can cause spurious protection trips in the primary and secondary battery-protection circuits. These trips can be a nuisance or, in the case of a secondary protection trip, may disable the battery.

Battery designers should follow good EM-noise-reduction techniques when designing the battery-management-system electronics. Careful PCB-trace routing and extensive use of ground-plane areas in the PCB are essential. Carefully bypass power distribution for the gas gauge and associated ICs because they receive their power directly from the cells. Proper connections between the gas-gauge IC and the current-measurement shunt are essential; consult vendor literature for recommendations. **EDN**

REFERENCES

- 1 "8- and 32-bit, low power high-performance MCU," Atmel, <http://bit.ly/gxt8sH>.
- 2 "Battery Management: Cell Balancing and Safety," Intersil, <http://bit.ly/fopJy1>.
- 3 "Parametric Search: Battery Protectors, Selectors, and Monitors," Maxim Integrated Products, <http://bit.ly/ff1usc>.
- 4 "Intelligent Battery," O₂Micro, <http://bit.ly/gLaTl3>.
- 5 "Battery Fuel Gauges," Texas Instruments, <http://bit.ly/i669aH>.
- 6 "Parametric Search: Lithium-ion Battery Protection ICs," Seiko Instruments Inc, <http://bit.ly/hixEKu>.
- 7 "Battery Management," Linear Technology, <http://bit.ly/eVkXTQ>.
- 8 "Self Control Protector," Sony Chemical and Information Device Corp, <http://bit.ly/gpZxSb>.
- 9 "SBS 1.1 specs: current," Smart Battery System Implementers Forum, <http://bit.ly/flw9NK>.

AUTHOR'S BIOGRAPHY

David Gunderson is a senior electronics engineer at Micro Power Electronics. He is responsible for design electronics and embedded software for batteries and chargers. Gunderson holds a bachelor's degree in electrical engineering, and his interests include composing and performing music and playing with his grandchildren.

PICO

DC-DC Converters
2V to 10,000 VDC Output

- Over 2500 Std. DC-DC Converters
- Surface Mount
- From 2V to 10,000 VDC Output
- 1-300 Watt Modules
- Isolated/Regulated/Programmable Models Available
- Military Upgrades Available
- Custom Models, Consult Factory

Delivery-Stock to one week for sample quantities

ISO9001:2000
ANAB BSI
AS 9100 REV B

for **FREE** PICO Catalog
Call toll free 800-431-1064
in NY call 914-738-1400
Fax 914-738-8225

PICO Electronics, Inc.
143 Sparks Ave. Pelham, N.Y. 10803
E Mail: info@picoelectronics.com
www.picoelectronics.com

All the Highs & a Low

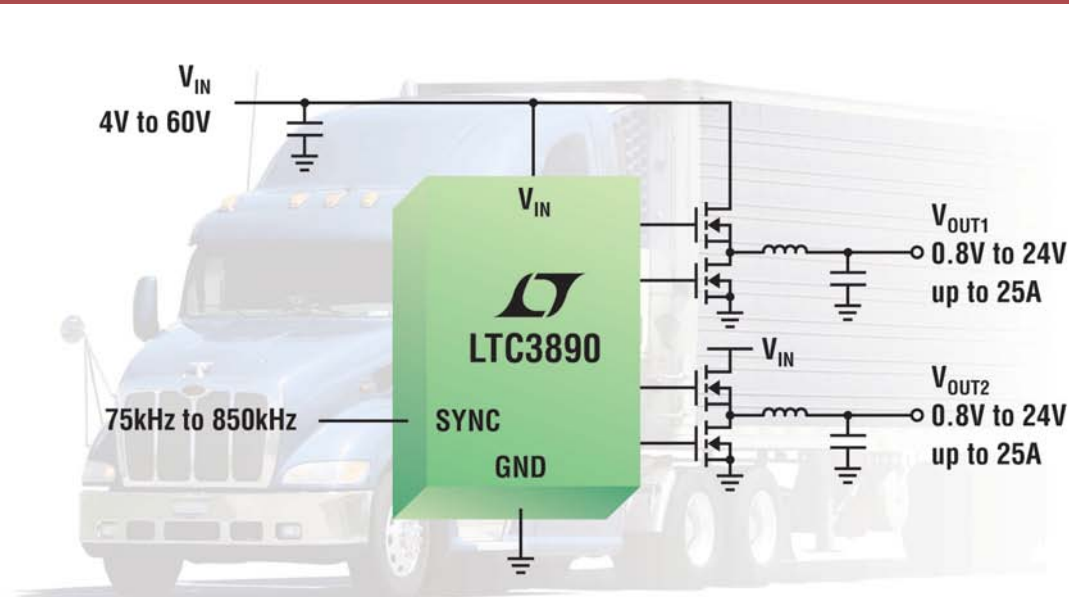

$60V_{IN}$, $24V_{OUT}$, 25A/Channel, 850kHz & $I_Q = 50\mu A$

A new generation of dual synchronous, micropower step-down controller, the LTC[®]3890 offers performance and feature advantages for a broad range of power conversion applications. The 4V to 60V input capability covers a wide range of input sources and battery chemistries, protecting against high voltage transients so surge suppression circuits are not required. Minimum on-time of 95ns enables high step-down ratios. Its powerful 1.1 Ω onboard N-channel MOSFET drivers can deliver up to 25A of continuous output current per channel.

Features

- Input Voltage Range: 4V to 60V
- Dual Output Voltages: Up to 24V
- Up to 25A Output per Channel
- 95% Efficient
- Low Quiescent Current: 50 μA
- Multiphase Capable for Higher Output Current & Low Input Ripple
- High Step-Down Ratios
- R_{SENSE} or Inductor DCR Sensing
- Single Output Version: LTC3891

Efficiency vs Output Current (A)

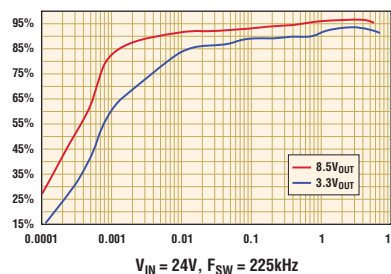

Info & Free Samples

www.linear.com/3890

1-800-4-LINEAR



www.linear.com/ad/3890

LT, LT, LTC, LTM, Linear Technology and the Linear logo are registered trademarks of Linear Technology Corporation. All other trademarks are the property of their respective owners.



designideas

READERS SOLVE DESIGN PROBLEMS

Test continuity with an LED

Raju R Baddi, Raman Research Institute, Bangalore, India

 You sometimes need to know whether a resistance exceeds a preset limit. The continuity tester in **Figure 1** lets you determine that fact for resistances of 0.5Ω to $10\text{ k}\Omega$. The heart of the circuit is the transistor pair comprising Q_1 and Q_2 , whose emitters draw current from a single source, R_E . Insert the circuit under test, R_{CY} , between Point A and Point B. To set the limit, use a known resistance for R_{CY} and set the trimming potentiometer until the LED begins to light.

The current through R_E divides between Q_1 and Q_2 in proportions based on the resistances of the two loops. The circuit lets you set the low limits to val-

ues as low as 0.5Ω because the emitter current in Q_2 can change rapidly with small changes in its V_{BE} (base-to-emitter voltage). The remaining current originating in R_E goes through the emitter of Q_1 , whose collector then suffers voltage changes on the order of approximately 100 mV because most of a transistor's emitter current flows to its collector.

At extremely low limits, a large change in emitter current can easily accommodate the drop in voltage across R_{CY} in Loop 2. The extra current goes through Loop 1. At the critical value of R_{CY} , Loop 1 conducts a much higher current than Loop 2, which again means a much smaller V_{BE} change for Q_2 .

DI's Inside

48 Flash an LED from ac-mains power

50 Reliable 555 timer doesn't falsely trigger

50 Transistors drive LEDs to light the path

51 Use an optocoupler to make a simple low-dropout regulator

▶ To see all of EDN's Design Ideas, visit www.edn.com/designideas.

The online version of this Design Idea, available at www.edn.com/110106dia, includes an appendix that provides

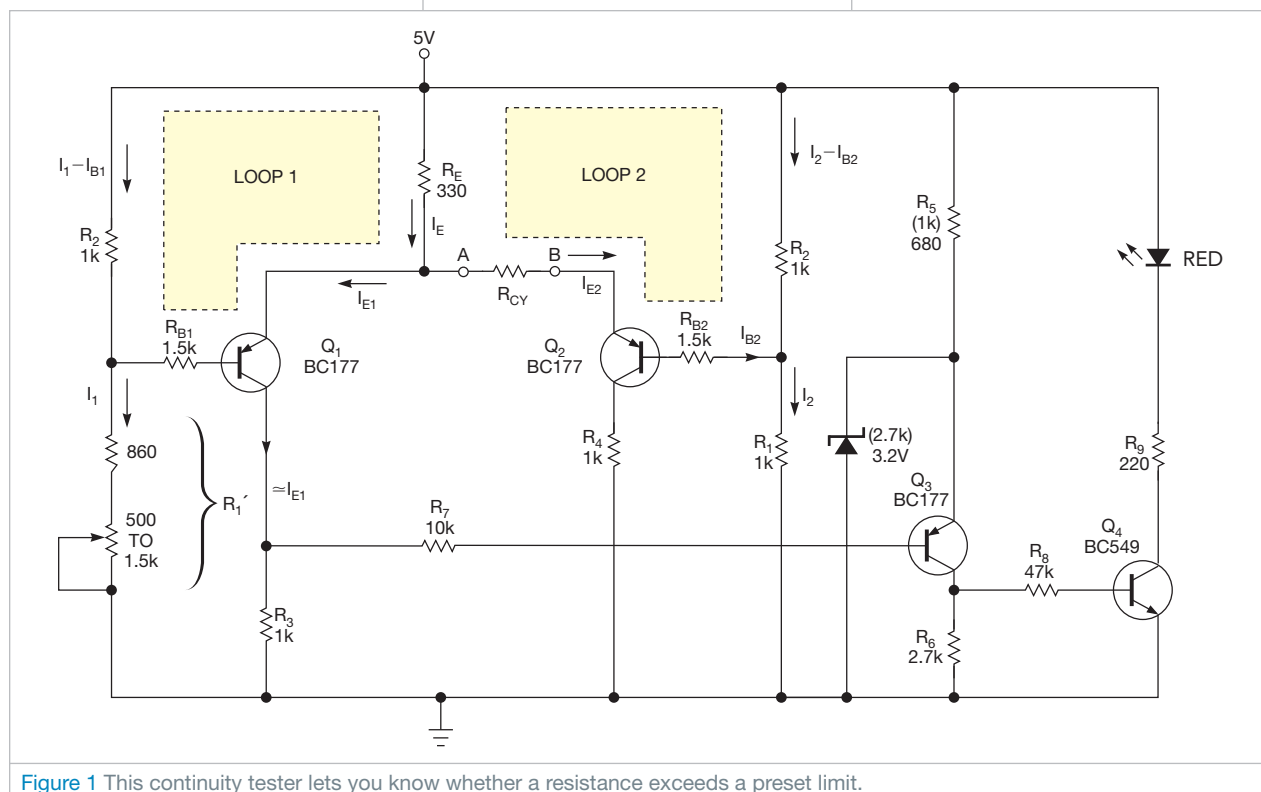

Figure 1 This continuity tester lets you know whether a resistance exceeds a preset limit.

a detailed analysis of the circuit's dc performance.

When R_{CY} is an open circuit or has a resistance above the set limit, a larger portion of the current through R_E flows to the emitter of Q_1 , which produces a voltage across R_3 . That voltage is close to the voltage at the emitter of Q_3 . Thus, Q_3 doesn't have sufficient V_{BE} to turn on. In turn, Q_4 is off, and the LED doesn't illuminate.

When the resistance of R_{CY} is under the set limit, Q_2 begins to draw its share of current from R_E . This step reduces the

current through the collector of Q_1 , and the voltage drop across R_3 also decreases. The difference in voltages between the collector of Q_1 and the emitter of Q_3 exceeds V_{BE} . Q_3 then conducts, turns on Q_4 , and lights the LED.

The tester's quiescent current is 10 mA, making the tester suitable for a bench instrument. If you need battery power, such as a 3.6V nickel-cadmium or lithium-ion battery, however, you can reduce the LED's series resistance by less than 47Ω and change Q_3 's emitter voltage. (See the appendix, which is available

online at www.edn.com/110106dia.)

Use two variable potentiometers in series whose values—1 k Ω and 100 Ω , for example—differ by an order of magnitude. This approach allows you to make precise limit adjustments at lower limits.

The values in parentheses in **Figure 1** are substitute values. You can substitute five 1N4148 diodes for the 3.2V zener diode. Both arrangements perform well. The LED may go a bit dim toward the low limit, approximately 0.5 Ω , so use one with a transparent lens.**EDN**

Flash an LED from ac-mains power

TA Babu, Chennai, India

 LED technology is opening the door to a variety of high-power-illumination applications. The circuit in **Figure 1** can let you know when ac power is available. To drive a power LED from the ac line requires a converter or a similar arrangement. In this circuit, a passive

circuit drives the LED with a constant current, you can use any LED color to suit the situation.

The circuit uses a simple DIAC (diode-alternating-current) relaxation oscillator, which activates a constant-current switching circuit comprising IC_2

circuit, resulting in a brief, intense flash of light from the LEDs.

High-voltage capacitor C_1 , part of the passive dropper, limits the current drawn from the power line, as the following equation shows:

$$I_{RMS} = \frac{V_{AC}}{X_{ACCAPACITOR}} = \frac{V_{AC}}{\frac{1}{2\pi FC}} = 2\pi FCV_{AC}$$

A 47 Ω metal-oxide resistor, R_1 , acts as an inrush-current limiter. Because the LEDs require a lot of energy, it's not feasible to directly drive them using a small-value capacitive dropper. Instead, this circuit uses a 2200- μ F capacitor, C_2 , to collect and store energy from the power line between flashes. Zener diode D_4 limits the capacitor voltage to 12V.

The easiest constant-current approach is to use an adjustable linear regulator, such as Linear Technology's (www.linear.com) LM317. The regulator maintains a voltage of 1.25V across series resistor R_5 . The 1.25V is the reference voltage of the regulator. Consequently, you can determine the load current with the following equation: $I_{LED} = 1.25/R_5$. The active current limiting is 320 mA, which is sufficient to produce an intense light flash.

As a note of caution, this circuit has no galvanic isolation from the ac mains. Most nodes are, therefore, at mains potential and hence dangerous. You should not construct this circuit unless you have experience in handling high-voltage circuits.**EDN**

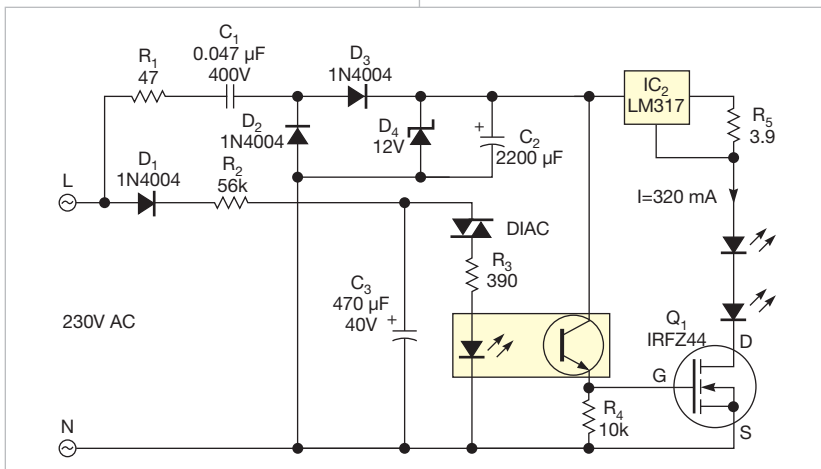

Figure 1 This circuit uses a simple DIAC relaxation oscillator, which activates a constant-current-switching circuit.

dropper greatly simplifies the total design. You can also simplify the circuit to run on dc power, which lets you use it from automotive batteries to supply light at night.

The design comprises an inrush-limiting resistor, R_1 ; a half-wave rectifier with a filtering capacitor comprising D_2 , D_3 , D_4 , and C_2 ; a relaxation oscillator; and two high-power LEDs. Because the cir-

and Q_1 . The DIAC turns on when capacitor C_3 charges through diode D_1 and resistor R_2 from the mains voltage. After a number of half-cycles of the mains, the voltage on C_3 exceeds the break-over voltage of the DIAC, the DIAC conducts, and C_3 discharges through R_3 and optocoupler IC_1 . The optocoupler activates the constant-current switching



Industry's lowest power supervisory IC...AGAIN!

Conserve battery life with Maxim's adjustable-timeout, 125nA watchdog solution

94% lower supply current than competition

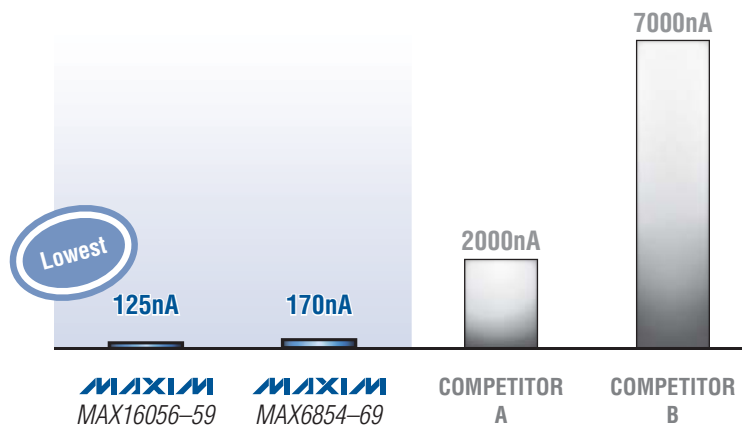

- Reset thresholds from 1.575V to 4.625V in 100mV increments
- Fully specified over the -40°C to +125°C automotive temperature range
- Capacitor-adjustable reset watchdog timeouts

Part	Watchdog Timer	Reset Output	Package
MAX16056	✓	Push-pull	8-TDFN
MAX16057	—		6-TDFN
MAX16058	✓	Open drain	8-TDFN
MAX16059	—		6-TDFN

Small Package



www.maxim-ic.com/MAX16056-9-info

**MAXIM
DIRECT.**

www.maxim-ic.com/shop

AVNET
electronics marketing

www.em.avnet.com/maxim

MAXIM
INNOVATION DELIVERED®

For free samples or technical support, visit our website.

Innovation Delivered is a trademark and Maxim is a registered trademark of Maxim Integrated Products, Inc. © 2011 Maxim Integrated Products, Inc. All rights reserved.

Reliable 555 timer doesn't falsely trigger

John Dawson, Opelika, AL

▶ Circuits employing the popular 555 timer circuits are often reliable under many conditions. When you use them in electrically noisy environments, however, the timer can produce a false trigger, no matter how well you filter its power-supply lines. The circuit in **Figure 1** sends a pulse to an SCR (silicon-

controlled-rectifier) crowbar circuit when the 555's input pulls low due to a fault-detection circuit. The 555 timer chip is unpowered until a crowbar fault signal occurs. The logic-low signal forces the 74LS02 NOR gate's output high, which provides enough power to operate to the 555 timer circuit. The timer trig-

gers on power-up. Capacitor C_2 holds the trigger signal low until it charges to 5V. The 555 timer's output should drive a low-current device—in this case, a transistor switch. This circuit solves the problem of false triggers. The pulse transformers connect to two SCRs in series that pulse 1600 to 2000V dc to fire a crowbar for a 22-kV dc power supply. The SCR-controlled high-voltage power supplies are electrically noisy, causing many false triggers from the 555 timer circuit. **EDN**

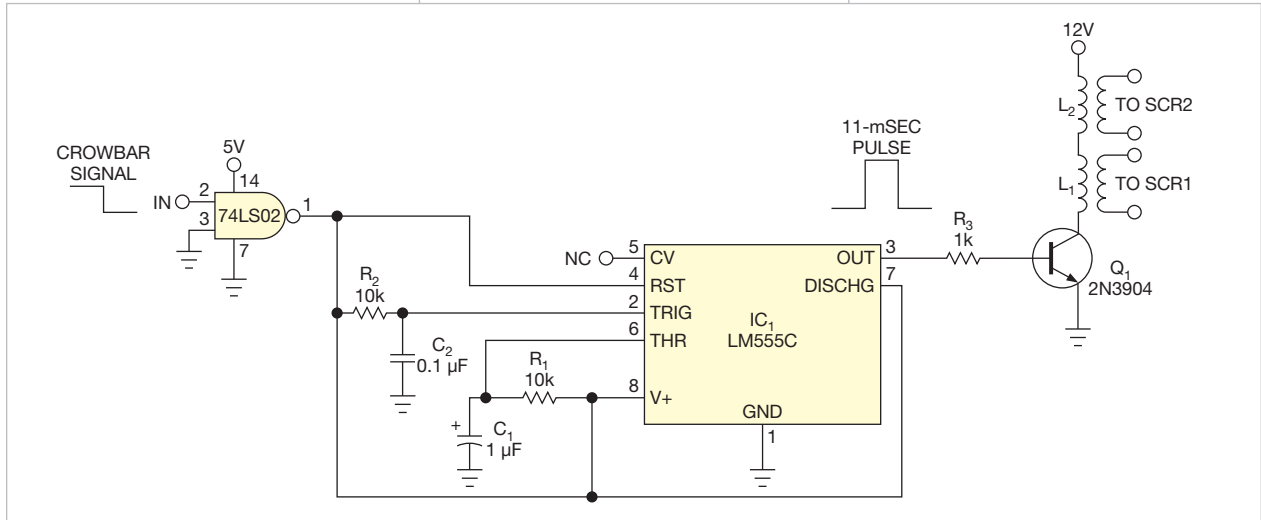

Figure 1 Powering the 555 timer from a NOR gate results in no false triggers from an electrically noisy environment.

Transistors drive LEDs to light the path

Eliot Johnston, Comnet International, Richardson, TX

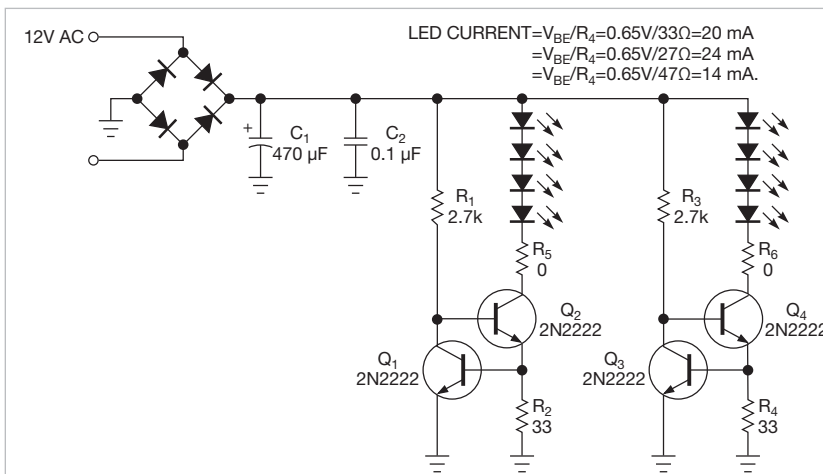

Figure 1 A simple two-transistor, two-resistor circuit is a good fit for outdoor-lighting applications.

▶ Keeping low-voltage outdoor lights illuminated takes some effort. Bulbs burn out, and connections corrode. HB LEDs (high-brightness light-emitting diodes) seem like acceptable replacements, but most are available only in surface-mount packages, which aren't conducive to a backyard project. In addition, you must create a reflector for tiered lighting. Low-power LEDs, which come in finished packages, are more appealing, but you must have a way to drive them. Numerous driver ICs are available, but they, too, usually are available in surface-mount packages. Furthermore, the cost of the parts can add up to an expensive project. The simple two-transistor, two-resistor circuit in **Figure 1** provides a better fit for this application.

The two transistors and two resistors act as a simple current source. Q_1 's base-emitter voltage, V_{BE} , combines with re-



Figure 2 Two identical circuits on a round PCB can drive eight LEDs, producing a relatively consistent light output.

sistor R_2 to set the LED current at approximately 20 mA. In this application, even a tolerance of $\pm 10\%$ doesn't significantly affect LED performance. Thus, only the value of R_2 is somewhat critical.

The 7 and 11W incandescent outdoor lights in this setup receive their power from a 12V-ac photoelectric timer. The bridge rectifier and filter capacitor produce approximately 15V dc—enough to drive four white LEDs, each with an approximately 3.2V forward-voltage drop. A small-value re-

sistor, R_3 , may be necessary to offload some of the power dissipation of the main pass transistor. In this setup, however, Q_2 dissipates only around 50 mW, so it can use just a jumper wire for R_3 —hence, the schematic shows it with a value of 0Ω . Two identical circuits on a round PCB (printed-circuit board) can drive eight LEDs, producing a relatively consistent light output using Cree (www.cree.com) C535A-WJN series 110° -viewing-angle LEDs (**Figure 2**).

The lighting network uses two 144W transformers, which probably consume

more energy than the new LED lamps. Once you replace all the bulbs with LEDs, power consumption should drop from approximately 200W to approximately 20W. You then connect the two strings together and remove one of the transformers. You could also build an ef-

SOLDER THE WIRES DIRECTLY TO THE PCB, LEAVING THE POTENTIAL FOR CORROSION AT THE CONNECTION TO THE MAIN WIRE.

ficient 120V-ac to 15V-dc power supply into the transformer housing and send dc down the wire rather than 12V ac.

You should use an automotive clear-coat spray to seal everything from moisture. This circuit should provide more than 10 years of service life. Contact corrosion causes reliability problems. Corrosion tends to set into the stab connection to the main wire and at the bulb itself. Instead of plugging in the replacement, you can solder the wires directly to the PCB, leaving the potential for corrosion at the connection to the main wire. Removing some insulation and soldering the wires makes for a more reliable connection. Remember to coat each splice with some silicon RTV (room-temperature-vulcanizing) sealant. **EDN**

Use an optocoupler to make a simple low-dropout regulator

Marc Ysebaert, De Pinte, Belgium

Although a monolithic low-dropout regulator has superior dynamic characteristics, the discrete regulator in this Design Idea is so simple that you can adapt it to many purposes. Using a common transistor, it has a dropout voltage of 0.1V. This dropout voltage can be even less if you use a FET. In the circuit in **Figure 1**, the optocoupler's LED determines the approximately 1V output

voltage, which the circuit adds to the voltage of the zener diode. A low-current zener diode gives the best results because regulation occurs at less than 1 mA, depending on the current gain of the transistor. To regulate the voltage of one battery cell, you can omit the zener diode to a given output voltage of approximately 1V. You can also replace the zener diode with a potentiometer to ob-

tain a variable output voltage. Another alternative is to use a combination of one or more LEDs or regular or Schottky diodes to obtain a fixed output voltage. You can insert a low-current LED as part of the voltage-reference branch to give an indication of the proper operation of the regulator.

The circuit in **Figure 1** consumes approximately 1 mA and starts to limit the current at currents higher than approximately 50 mA. With a lower value for the resistor, the LED glows brighter, the output voltage is slightly higher, and the current consumption and the current limit are proportionally high-

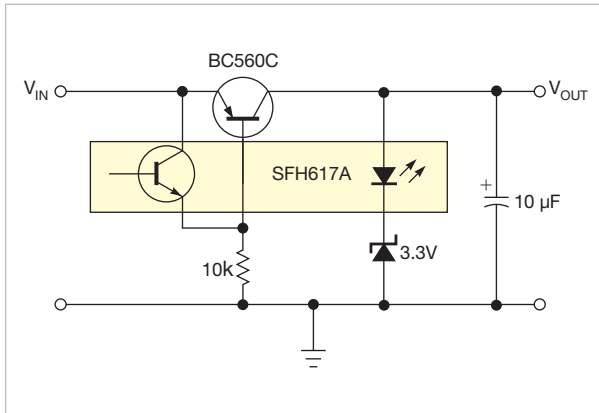

Figure 1 This simple low-dropout circuit is ideal for higher voltages that a zener diode sets.

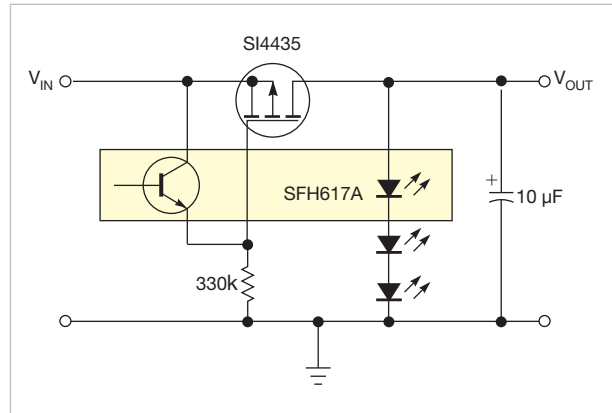

Figure 2 Using LEDs or diodes makes the circuit suited for lower regulation voltages.

er. You can replace the transistor and the optocoupler with almost any other type, but a high current gain and transfer ratio are preferable. When you use a high-voltage transistor, the input voltage can be much higher than is possible with common monolithic regulators. You can use a Darlington transistor for

higher currents if your design can tolerate a dropout voltage of 0.7V. An output capacitor with a value of approximately 10 to 47 μF is necessary to avoid oscillation. Higher values are necessary for higher output currents. The circuit requires no input capacitor.

The circuit in **Figure 2** replaces the

transistor with a P-channel FET and uses a 330-k Ω resistor. In this configuration, the circuit consumes about 50 μA and should suit many battery-powered devices. There is no inherent current limiting. You can reduce R_1 to 10 k Ω or lower to have a faster response to load change and to obtain a visual indication with the LEDs. **EDN**

EDN[®] CUSTOM REPRINTS

VOICE OF THE ENGINEER

Use reprints to build your marketing initiatives and strengthen your company.

HELP YOUR

EDITORIAL

EXPOSURE

STAND OUT.

REPRINTS ARE IDEAL FOR:

- New Product Announcements
- Sales Aid For Your Field Force
- Customer & Prospect Presentations
- Direct Mail Enclosures
- Trade Shows/Promotional Events
- PR Materials & Media Kits
- Conferences & Speaking Engagements
- Recruitment & Training Packages

1 – 100 Hard Copy Reprints Available! Visit landing.fosterprinting.com/canoncommunications

For additional information, please contact Foster Printing Service, the official reprint provider for *EDN*.

Call 866.879.9144 or sales@fosterprinting.com

F O S T E R

PRINTING SERVICE

supplychain

LINKING DESIGN AND RESOURCES

Inventory's bumpy road to smooth somewhat this year

Component inventory in 2010 saw two- to three-times-longer-than-normal leadtimes. Component suppliers quickly and severely ratcheted back production in late 2008 in response to the recession; 2010 then came roaring back with unexpected demand, even as the macroeconomy was still struggling. Manufacturers reduced inventory, especially passives, as they first turned on their lines for their high-margin components.

OEMs, contract manufacturers, and franchised distributors have worked to build up inventories, but there hasn't been enough to go around. With shortages in such basic parts as tantalum capacitors, aluminum capacitors, relays, nichrome film resistors, and some inductors, manufacturers can't solve the problem at the design level. Last year (2010) was a boom one for independent distributors as cheap parts suddenly skyrocketed in price.

Many in the industry believe that inventory will come closer to balance in 2011, when leadtimes should decrease as component manufacturers ramp up production. Uncertainties about the global economy, however, are prompting caution, so inventory levels will likely stay low. One wild card in the mix is raw materials. Shortages in tantalite, nickel, copper aluminum, zinc, palladium, and silver are sending prices up.

Recent changes in both demand and production are beginning to take some of the



edge off shortages in the market. "[In October], we saw demand soften a bit, yet decreases in demand are coming off record months and demand is still above historical averages," says Dustin Ford, vice president of South Asia at Smith & Associates (www.smithweb.com), an independent distributor. "Some leadtimes have come down, and push-outs on scheduled orders have occurred with some customers."

Early in 2010, demand shot up at an expected rate. "Throughout the channel, a lot of product inventory has been pretty scarce," says Michael Knight, vice president of supplier management and product management at TTI Inc (<http://ttiinc.com>). "It's been tough for anyone to accumulate inventory. We're starting to catch up. We're seeing inventory begin to recover. As 2010 wore on, demand continued to increase beyond the overall economy, and leadtimes quickly became longer."

"Across our 400 suppliers, the average leadtime is usually 20 to 25 days," says Colin Campbell (photo), vice president of distribution at Newark (www.newark.com). "We saw that [time] go

to 45 and nearly 50 [days] in the second quarter [of 2010], almost doubling. We're starting to see that come down to a manageable level. [Component manufacturers] have improved their production, and our systems have adjusted to the longer leadtimes."

You can attribute many of the shortages in 2010 to component manufacturers' quick moves to reduce capacity. Rather than getting caught with a mountain of inventory, as in 2000, manufacturers cut capacity. According to Todd Ballew, executive vice president and general manager at World Micro Inc (www.worldmicro.com), a components distributor, "2008 and 2009 were the years when supply was greater than demand, so component manufacturers were really backing off their facilities. In 2010, we started to see demand, and [component manufacturers] responded by producing the most valued products first. That [step] caused downstream shortages."

Component manufacturers sliced capacity beginning in 2008 when the economy began to slip. They are not likely to rush into capacity investment before they're sure of sustained demand. "Semiconductor manufacturers put limits on orders throughout 2010 to help contain the dreaded bullwhip effect from double booking during demand upswings," says Ford. "This [situation] has helped fuel demand in our market as frustrated customers turn to [independent distributors]

to keep their lines moving."

Another reason for the shortages of 2010 was a surprisingly sharp increase in demand. New products, such as tablets and smartphones, drove consumer purchasing even in a weak economy. "The capacity cuts that happened were pretty dramatic," says TTI's Knight. "Then, demand came back very quickly. It took through the first half of 2010 before anyone was willing to add capacity. The demand is still surprising."

One of the big unknowns comes from global economic forces. The current electronics boom is meeting with a sluggish macroeconomy. "The macroeconomic uncertainties should keep semiconductor manufacturers cautious about their capacities. Any increase in inventory levels should lean out, keeping leadtimes long and prices high," says Ford. "Uncertainties are looming across the globe. Uncertainties mean poor forecasting and inefficiencies throughout the supply chain. We see that well into 2011."

Even amid the uncertainties, many expect the electronics industry to reach a reasonable balance between demand and supply in 2011. "Capacity is catching up, but we're still seeing some pockets of problems. It's vendor-specific," says Newark's Campbell. "I think we're seeing a balance for 2011. There will be pockets of imbalance; there always are. But, generally, we see things coming more and more in balance."

—by Rob Spiegel



The West Coast's Project Acceleration
Resource for Electronics Manufacturing

Electronics[®] WEST

February 8-10, 2011

Anaheim Convention Center
Anaheim, CA

Your face-to-face meeting place for
the latest technologies in electronics
manufacturing, including:

- Assembly Board Inspection
- Components
- Contract Services
- Production Machinery
- Software
- Subassemblies
- Test & Inspection Products

... and much more



Supported by:

EDN

**CIRCUITS,
ASSEMBLY**
The Journal for Surface Mount and Electronics Assembly



Go Online and Register TODAY:
ElectronicsWestShow.com

Please use Promo Code AA

productroundup

DISCRETE SEMICONDUCTORS



MOSFETs come in compact packages for space applications

↘ The IRHLNM77110SCS and IRHNM5x7110SCS hermetic, 100V, radiation-hardened MOSFETs come in surface-mount SMD 0.2 packages for applications such as satellite-bus-power systems and payload power supplies. The package uses aluminum-nitride ceramic for enhanced thermal conductivity and addresses requirements for reduced system weight and size. The devices have a 0.3x0.2x0.1-in. (8x5x3-mm) footprint and weigh only 0.25g. Both 100- and 300-krad dose ratings are available, with a single-event-effect rating of 85 mg/cm². Standard and logic-level N- and P-channel devices are also available, and voltages other than 100V are available on request. Prices range from \$371 to \$465 (100).

International Rectifier, www.irf.com

Medical MOSFETs for implantable systems feature on-resistance as low as 0.40Ω

↘ The SMMA511DJ and SMMB-912DK family of power MOSFETs targets use in implantable medical systems. The series includes the 12V N- and P-channel SMMA511DJ MOSFETs in the PowerPAK SC-70 and the 20V dual N-channel SMMB912DK MOSFETs in the PowerPAK SC-75. The MOSFETs tout high quality and reliability with enhanced quality-control gates for every lot: statistical-bin-limit, statistical-yield-limit, and part-average-testing controls for wafers and component packages and homogeneous reliability testing for all wafer lots. The rigorous SMM medical-MOSFET-process flow also includes an acceptable

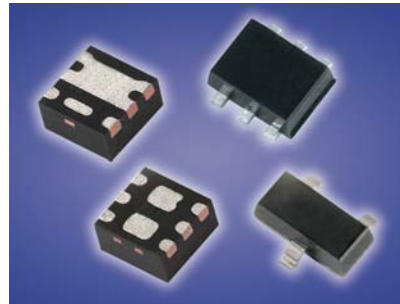

quality level of 0.04%. Applications include load switching in drug-delivery systems, defibrillators, pacemakers, hearing aids, and other implantable devices. They come in package sizes of 2x2 mm for the SMMA511DJ and 1.6x1.6 mm for the SMMB912DK, which help save space in miniaturized medical devices, and on-resistance as low as 0.040Ω lowers conduction losses and maximizes battery life. Prices start at \$1.03 (10,000).

Vishay Siliconix, www.vishay.com

EDN ADVERTISER INDEX

Company	Page	Company	Page
Agilent Technologies	4	Linear Technology	19-20, 46
Analog Devices Inc	13	Maxim Integrated Products	49
Anaren	25	Mill-Max Manufacturing Corp	11
APEC 2011	29	Panasonic Industrial	55
Digi-Key Corp	C-1, 3	Pico Electronics Inc	44, 45
EMA Design Automation	58	Renesas Technology Corp	6
International Rectifier Corp	7	Stanford Research Systems Inc	57
Lambda Americas	41	UBM Canon Trade Events	10, 43, 54
Lattice Semiconductor	2	Vicor Corp	15
LeCroy Corp	8		

EDN provides this index as an additional service. The publisher assumes no liability for errors or omissions.

EDN product mart

This advertising is for new and current products.



WIRELESS RF MODULES

Highly flexible, cost effective RF Modules for a wide variety of wireless Personal Area Network (PAN) applications. Extended range products featuring small footprints combined with revolutionary network firmware flexibility. Available in 802.15.4, Bluetooth®, ISM and Relative Position Awareness (RPA) technologies.



www.panasonic.com/indus/rf/

piccomponentsmarketing@us.panasonic.com
1-800-344-2112

An engineer walks into a bar ...



In 1995, I was working at a large conglomerate that had once competed with Thomas Edison but whose remainders exist only in entertainment. I had to design a voltage-attenuator box for use with a new three-phase power-measurement board. I found a precision ceramic part with matched resistors. This type of part typically finds use in precision laboratory meters. To minimize heat generation, I chose a part with 10-M Ω resistance and eliminated the analog multipliers of previous designs. Instead, I digitized the raw current and voltage waveforms and performed multiplication in software using the two-wattmeter method. I thought this design clever for a guy with only mechanical-engineering degrees.

When the first prototype was ready, the validators reported strange results on a real motor. The measured power was different depending on how the leads were connected, which shouldn't have mattered. It got even more confusing when I tried to reproduce the problem and saw no difference.

After much time stroking the motorized valve, I finally realized that the other engineer was reversing the motor direction each time, to keep from running out of stem travel. We had a laugh when we finally realized that this rever-

sal was the problem, and I was then able to reproduce the problem.

For some reason, however, this humorous story didn't translate to my wife. It also met with awkward silence when related at cocktail parties, even when explained in meticulous detail. "See, each time I swapped the leads, behind my back he would push the red button instead of the green button, or vice versa," I commented. Engineering humor will always be an acquired taste.

The lone electronics engineer at the company was sure that my "risky idea" to

use software multiplication was causing the problem. I knew better and quickly traced the problem to an inadvertent phase shift of the voltage waveforms. The company that designed the PCBs (printed-circuit boards) had thoughtfully added small capacitors to the input lines to filter noise, which formed an RC filter with the output resistance of the attenuator.

EACH TIME I SWAPPED THE LEADS, BEHIND MY BACK THE OTHER ENGINEER WOULD PUSH THE RED BUTTON INSTEAD OF THE GREEN BUTTON, OR VICE VERSA.

This design approach proved fortuitous because, even after snipping the capacitors, a small but significant phase shift occurred from just the 50-pF/ft cable capacitance. We might have not noticed this shift without the occurrence of the larger error.

We corrected the error by changing to an attenuator chip with 1-M Ω resistance. We still had to account for phase shifts in the clamp-on current probes, but we characterized those shifts in the laboratory and compensated for different probe models in software.

Our field engineers much appreciated the final system because the attenuator boxes were no longer married to the cards as in previous designs, and they were no longer locked to a single current-probe model tuned to the card. Most important, test leads no longer popped off the "bugger-picker" probes in the middle of a test.

Three rules have served me well in analog design ever since: Everything has capacitance, all wires have resistance, and most people don't get engineering humor. These rules always matter, whether you care about millivolts—or cocktail humor. **EDN**

William M Grissom is an engineering specialist at Aerojet (Sacramento, CA).

www.edn.com/tales

Powerful, Versatile and Affordable...

100 kHz Dynamic Signal Analyzer



SR785 ... \$11,950 (U.S. list)

- **DC to 100 kHz frequency range**
- **100 kHz real-time bandwidth**
- **Dynamic range**
 - 90 dB (FFT)**
 - 145 dB (swept-sine)**
- **Low-distortion (-80 dBc) source**
- **Up to 32 Mbyte memory**
- **GPIB and RS-232 interfaces**

FFT analyzers starting at \$4950

The SR785 Dynamic Signal Analyzer offers state-of-art performance at a fraction of the cost of competitive analyzers. Standard features include swept-sine mode, order tracking, octave analysis, curve fit/synthesis, and arbitrary waveform source.

When compared to the Agilent 35670A, the SR785 comes out on top. It offers twice the frequency range (2 ch.) and 10 times the real-time bandwidth at less than half the price of the 35670A.

The SR785 is ideal for filter design, control systems analysis, noise measurement, audio or acoustical test, and mechanical systems analysis.

Take a close look at the SR785.



Stanford Research Systems

1290-D Reamwood Ave., Sunnyvale, CA 94089 • e-mail: info@thinkSRS.com
Phone (408) 744-9040 • Fax (408) 744-9049 • www.thinkSRS.com

OrCAD MAKES IT POSSIBLE AUTOWIRE

GET CONNECTED FASTER THAN EVER

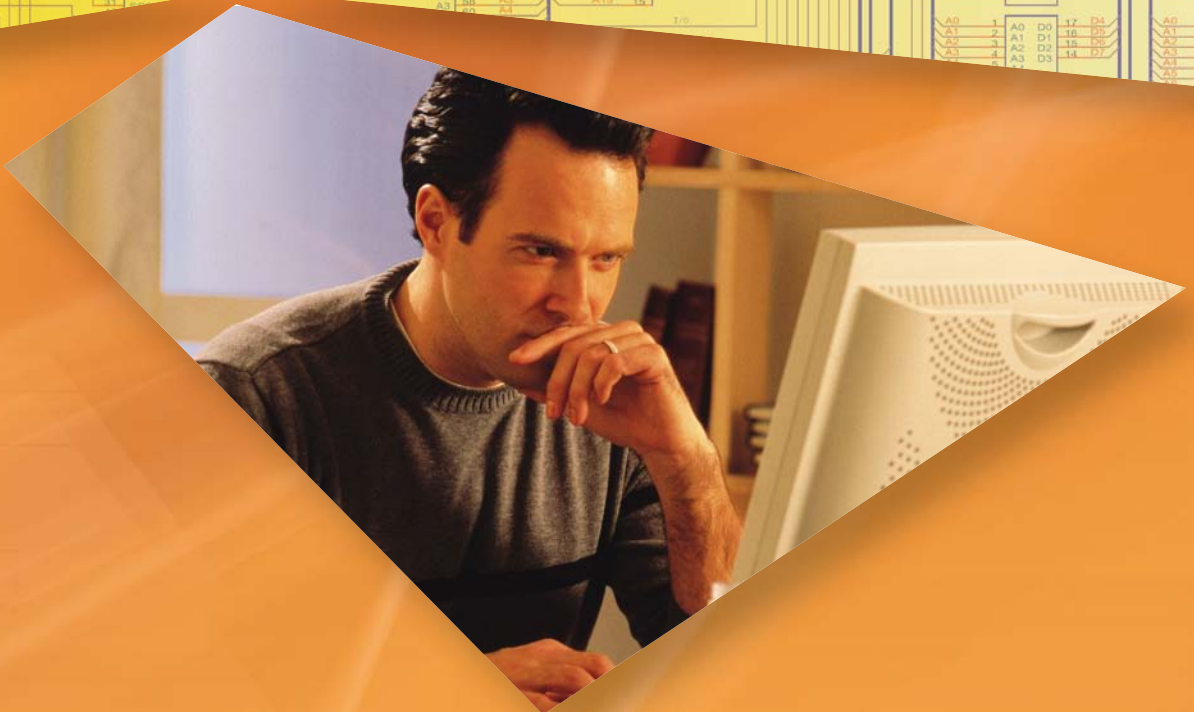

Wouldn't it be nice if wiring could be done automatically, and intelligently?

OrCAD® makes it possible with the new Autowire feature in Cadence® OrCAD Capture 16.3. With this new functionality, wiring between component pins on a schematic is as simple as selecting a starting pin and a destination pin and letting the software add the connection – all automatically and quickly.

Truly scalable PCB technology

Cadence OrCAD PCB design technologies comprise a complete, cost-effective PCB design solution, from design capture to final output. To successfully meet project goals, PCB designers and electrical engineers need powerful, intuitive, and integrated technologies that work seamlessly across the entire PCB design flow. OrCAD PCB design technologies offer fully integrated front-end design, analog/signal integrity simulation, and place-and-route technologies that boost productivity and shorten time to market.

OrCAD makes it possible

To learn more about the power and productivity gains made possible in the latest OrCAD releases, call EMA Design Automation, a Cadence Channel Partner, at 877.362.3321, e-mail us at info@ema-eda.com, or visit us online at www.ema-eda.com/orcadpossibilities.

Scan with
smartphone
for movie



cadence®

EMA Design
Automation™
Cadence Channel Partner

© 2010 Cadence Design Systems, Inc. All rights reserved. Cadence, the Cadence logo, OrCAD, PSpice are registered trademarks of Cadence Design Systems, Inc. All others trademarks are the property of their respective holders.